

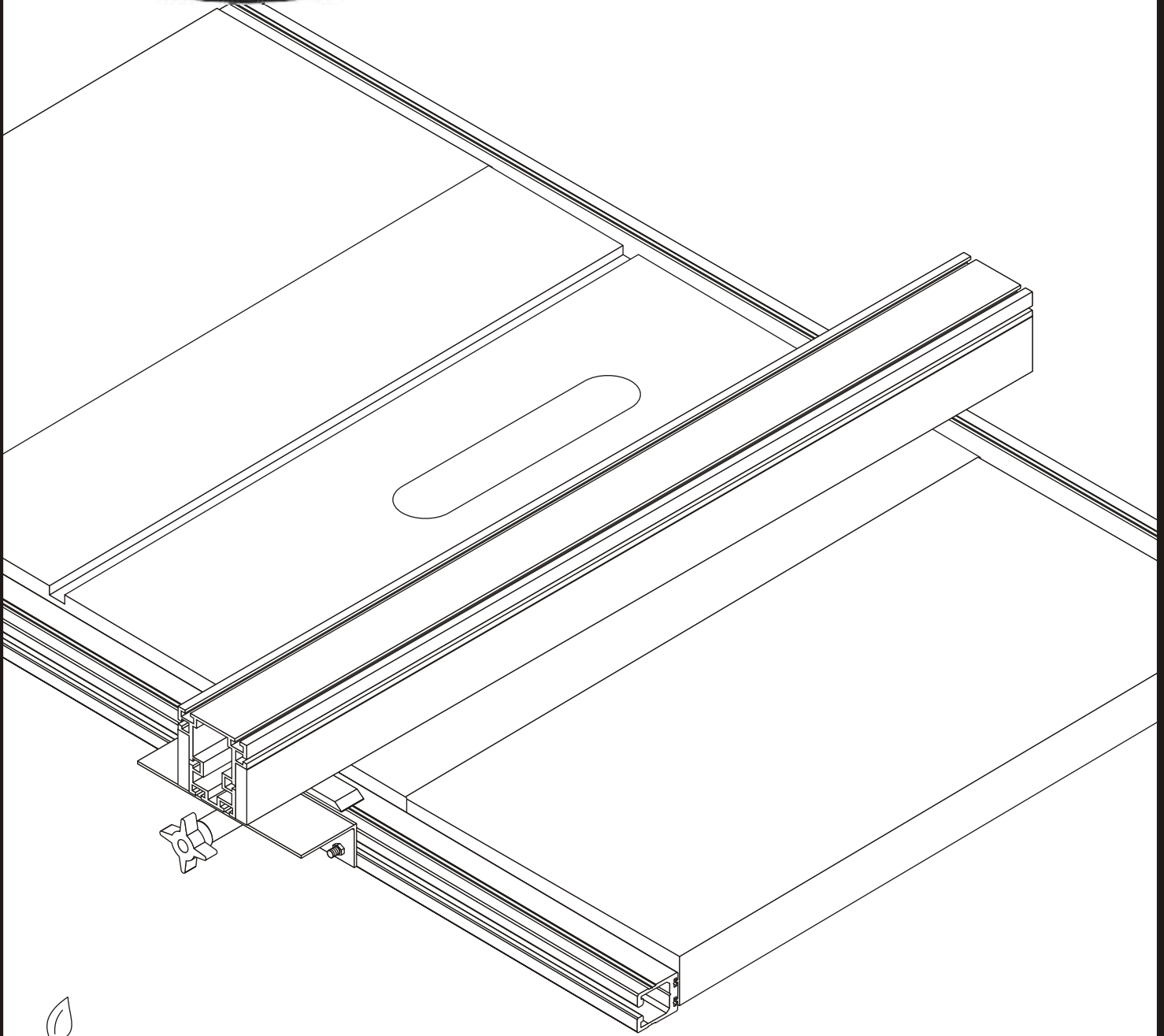

INSTRUCTION MANUAL



Peachtree Woodworking Supply, Inc.
3250 Oakcliff Industrial Street
Atlanta, GA 30340

www.ptreeusa.com



The EZ SQUARE TABLESAW FENCE

Table of Contents

TABLE OF CONTENTS	1
SAFETY GUIDELINES	2
PARTS DIAGRAM	3
ASSEMBLE THE FENCE CARRIAGE	4
INSTALLING THE FENCE RAILS	5-6
INSTALLING THE FENCE CARRIAGE	7
MOUNTING THE FENCE TO CARRIAGE	8
MOUNTING THE CURSOR	9
INSTALLING THE REAR FENCE BRACKET	10
ADJUSTING FENCE PARALLELISM	11
ADJUSTING FENCE VERTICAL SQUARE	12
INSTALLING THE MEASUREMENT TAPE	13



SAFETY GUIDELINES

Thank you for your purchase of the EZ Square Table Saw Fence. The EZ Square Table Saw Fence has been designed to fit virtually any table saw and installs in a few minutes.

Woodworking projects can be fun and rewarding, however safety comes first. Please read and follow the safety instructions that come with your fence and table saw before starting any projects.

WARNING: Failure to obey these warnings could lead to serious injury.

1. Read, understand and follow all the operating instructions provided with your table saw.
2. Read, understand and follow all the instructions provided with this fence system.
3. Always disconnect power from the saw before performing maintenance, repairs, blade adjustments, blade replacement and the installation of this fence system to prevent injury from accidental power up.
4. Keep all factory guards in place when installing this fence system.
5. Insure that there is adequate working room around your saw free from trip hazards.
6. Always wear safety glasses and hearing protection while working with power tools.
7. Be sure to keep hand and fingers a safe distance away from blade while it is turning.
8. Always support long boards on both the infeed and out feed side of your saw.

WARRANTY

Your EZ Square Table Saw Fence comes with a 30 day money back guarantee. If you are not completely satisfied, simply return it to us with the original packaging along with a copy of the receipt, and we will be happy to issue a refund for the purchase price paid. If you have any questions with the installation of your fence please call us at 770-458-5539.

Peachtree Woodworking Supply, Inc. employees, officers, authorized distributors and retailers will not be held responsible for damages or injuries resulting from the misuse or improper installation of this product.



Parts Diagram

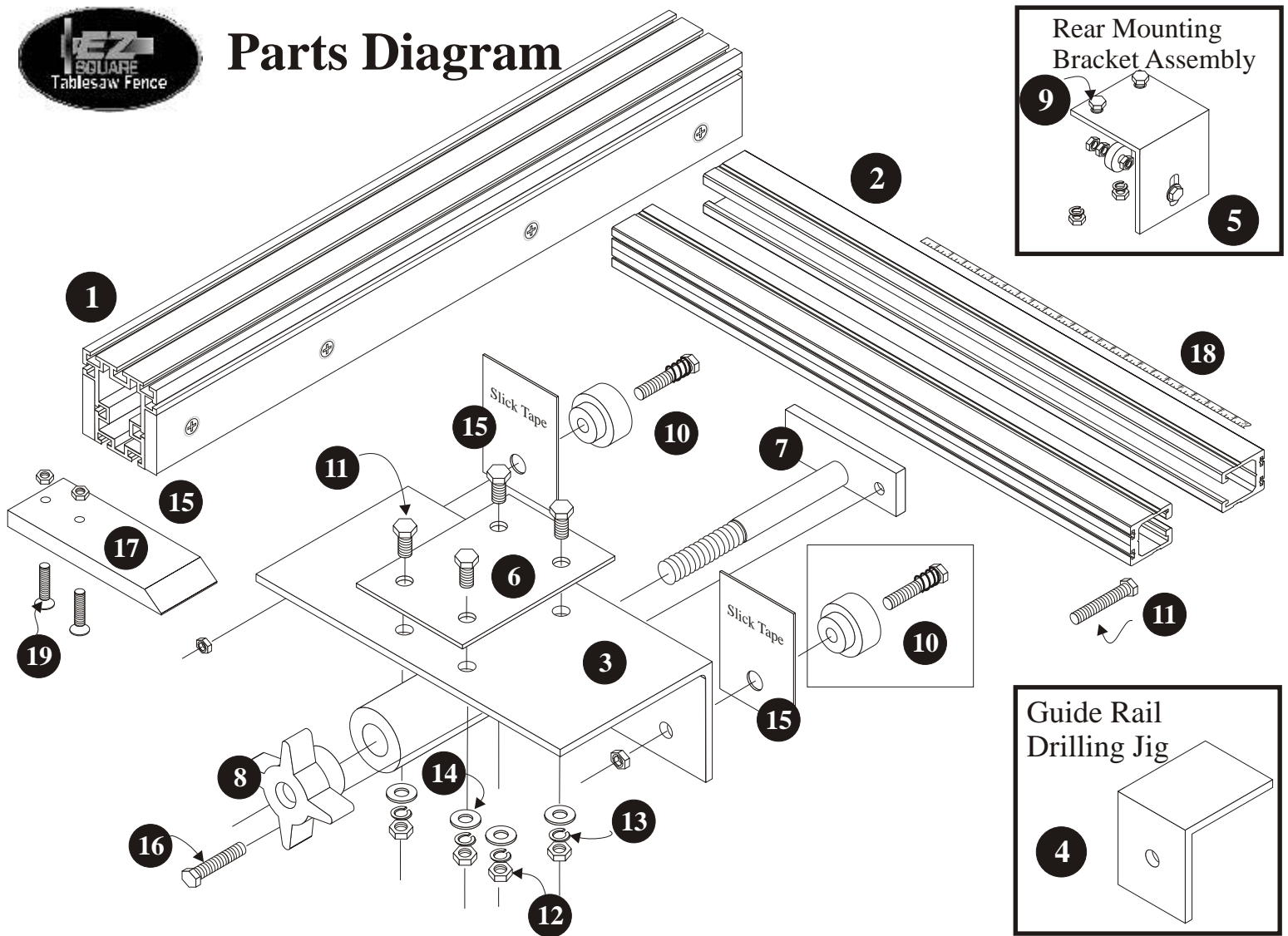

Part Number	Quantity	Description
1	1	Table Saw Fence
2	2	Fence Guide Rails
3	1	Fence Carriage
4	1	Guide Rail Drilling Jig
5	1	Rear Fence Mounting Bracket Assembly
6	1	Fence Spacer
7	1	Locking Bar
8	1	Locking Knob
9	2	1/4" x 3/4" x 20 TPI Bolt (Rear Bracket)
10	2	Roller, Spring and Bolt
11	16	1/4" x 1" x 20 TPI Bolts
12	22	1/4" Nut
13	6	1/4" Lock Washer
14	6	1/4" x Flat Washer
15	2	Slick Tape
16	1	1/4" x 1 1/2" x 20 TPI Locking Bar Guide Bolt
17	1	Cursor
18	1	Tape Measure
19	2	1/4" x 3/4" x 20 TPI Machine Screw



Assemble The Fence Carriage

Step 1

Attach the two Sticky Tapes (Part # 15) to the Fence Carriage Pads (Part #3).

Step 2

Install the Rollers, Springs, and 1/4" Bolts (use the 1/4" bolts that are only partially threaded) the non threaded portion of the bolt is were the Spring goes.(Part #10) as shown in the assembly drawing below. Secure with 1/4" nut (Part #12).

When installing the Roller, Spring and Bolt (Part #10) as one assembly, screw the bolt with the Roller and spring through the Carriage (Part #3) until there is approximately 3/8" thread showing through the Carriage and secure with a 1/4" nut (Part #12) on the Locking Knob side of the Carriage Bracket.

Step 3

Screw the Locking Bar Guide Bolt (Part #16) through the threaded hole in the Fence Carriage (Part #3) and tighten the bolt head fully to the Fence Carriage. This bolt prevents the Locking Bar from swiveling.

Step 4

Slide the Locking Bar (Part #7) through the hole in the Carriage (Part #3) while guiding the guide hole over the Locking Bar Guide Bolt (Part # 16) secure the Locking Guide Bar in the Fence Carriage with the Locking Knob (Part #8).

With the Carriage Assembly Complete set it aside for now and continue to Installing the Fence Rails Page #5.

Assembly Drawing

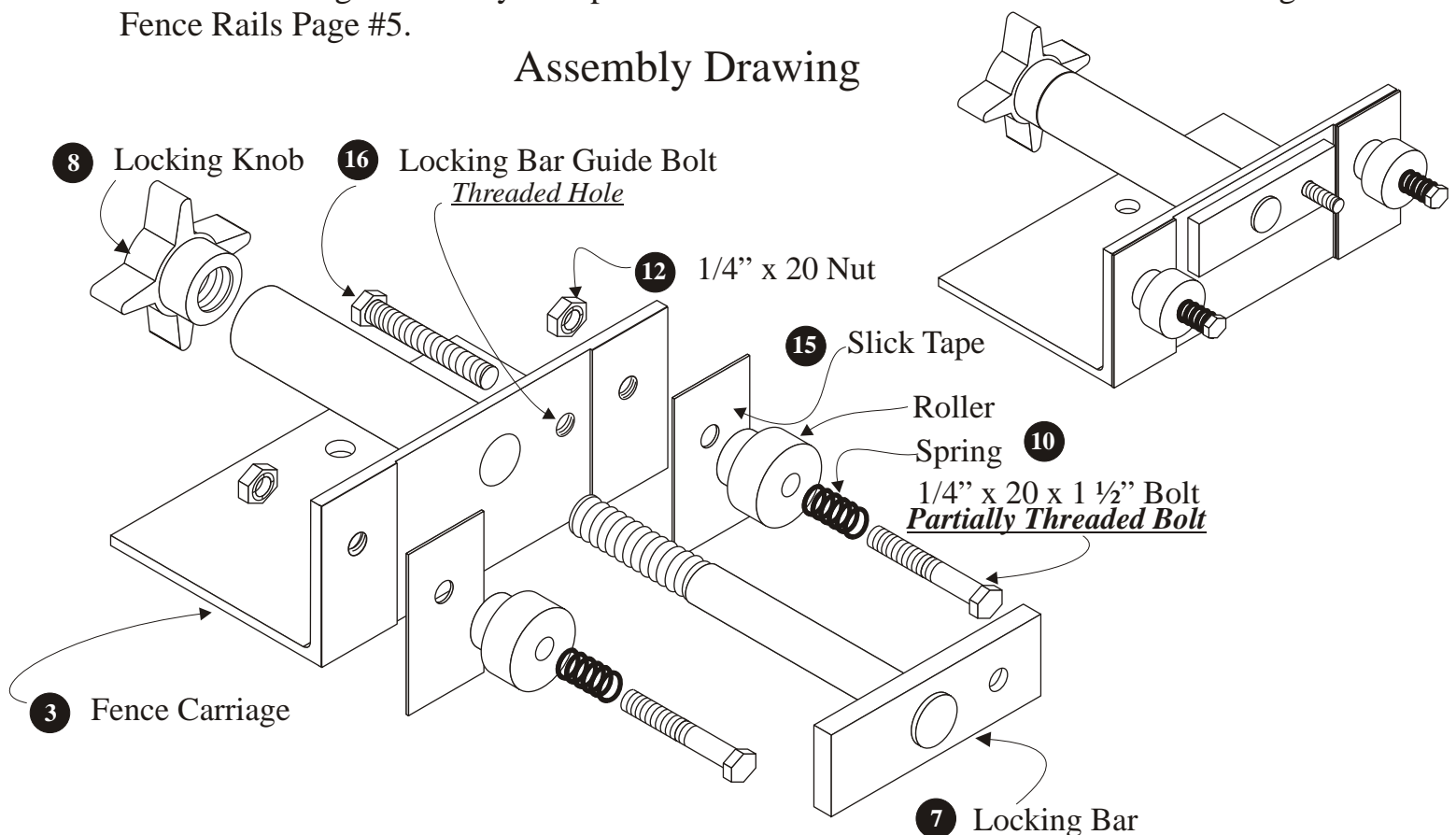



Installing the Fence Rails

Step 1

Remove any existing saw fence and all of its mounting hardware.

Step 2

Thoroughly clean the table saw top to include the underside of the front and back edges.

If the holes in your table saw table do not line up with the hole in the Guide Rail Drilling Guide (Part #4) you will have to do the following step.

Step 3

Using the Guide Rail Drilling Jig (Part # 4) mark the locations to be drilled for the Rail Mounting Bolts (Part #11) (the fence rail should have a mounting bolt approximately every 12" from the center out and approximately 2" from the ends) as follows:

(A) From the front center on the in feed side of the saw table top, place the drilling guide with the hole side against the edge of the top. Mark the 1/4" hole location with a pencil or scribe as shown in (Figure#1) at every 12" left and right from the center of the saw top then 2" in from each end. Inspect the back side of the location you just marked to insure there is no casting rib or obstruction which would prevent the placement of the bolt, washer and nut through the edge of the top for mounting the Fence Rails.

(B) Using a hand power drill and a 1/4" drill bit, drill through the table top edge at the marked location.

(C) Repeat the above procedure for the outfeed side of your table saw top.

Note: Check the back side of each drilled hole for burrs. Remove any burrs with a file to prevent false locking of washer and nut.

Step 4

Install the 1/4" x 20 x 1" bolts, flat washer and 1/4" locking nut through the holes drilled in the in-feed and out-feed table edges with bolt head to the out side edge. Leave the bolt loose with about 1/4" of threads showing to the out side of the table see (Figure 2). If your edge of your table is thicker than 1/4" you may need to use longer mounting bolts.

Note: The bolts must be left loose to allow for the Fence rails to slide on.

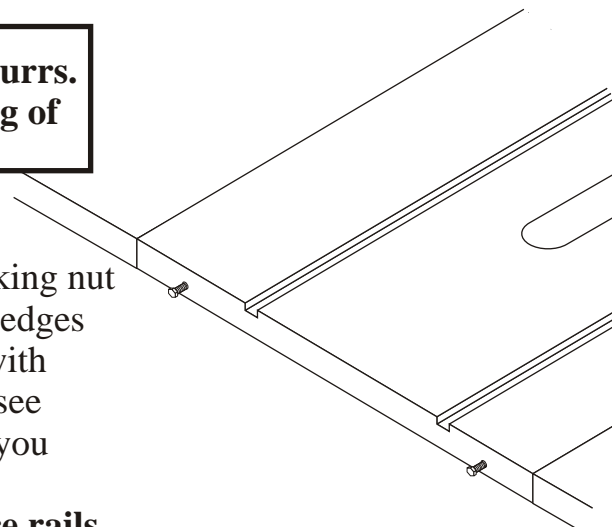
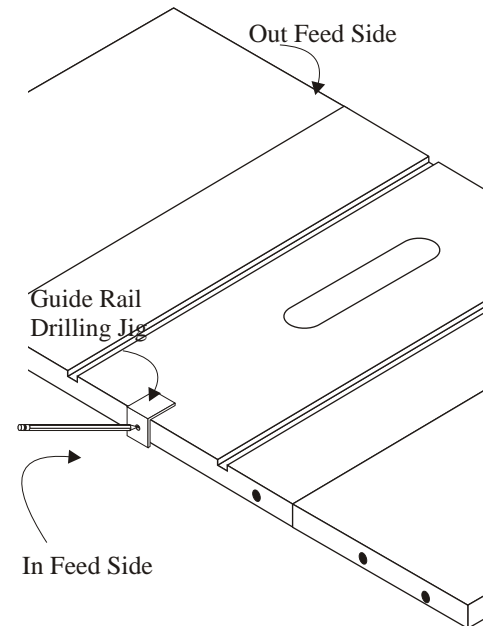



Installing the Fence Rails Continued

Step 5

Install the Saw Fence Rails by sliding the Rails (Part #2) on the 1/4" bolt heads using the top t-track slot as shown in Figure #3. Position the Rails to obtain the desired rip distance from the right or left side of the saw blade.

The EZ Square Table Saw Fence rails can easily be adjusted to the left or right to gain more cutting distance from the saw blade. To adjust the fence rails loosen all the 1/4" nuts on the fence rail mounting bolts and slide the rail left or right.

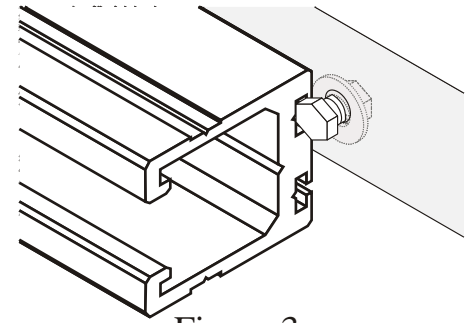

Figure 3

More cutting distance right of the saw blade (Figure 5).
More cutting distance left of the saw blade (Figure 5A).

Check to see that the front and back Fence Rails are slightly below the bottom of the miter gauge slot. (Figure #4). Tighten the fence mounting bolt nuts from the back edge of the table top to secure the rails in place.

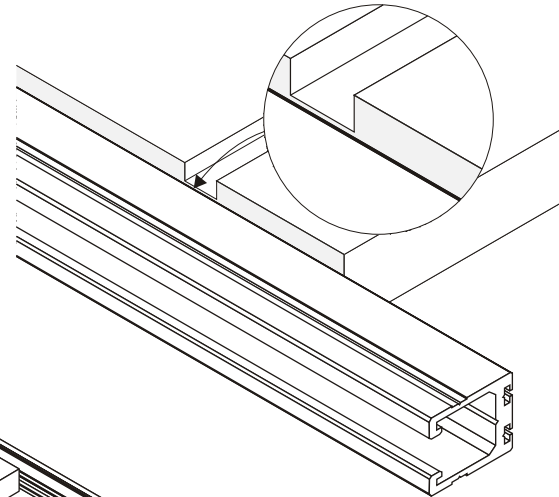

Figure 4

Figure 5

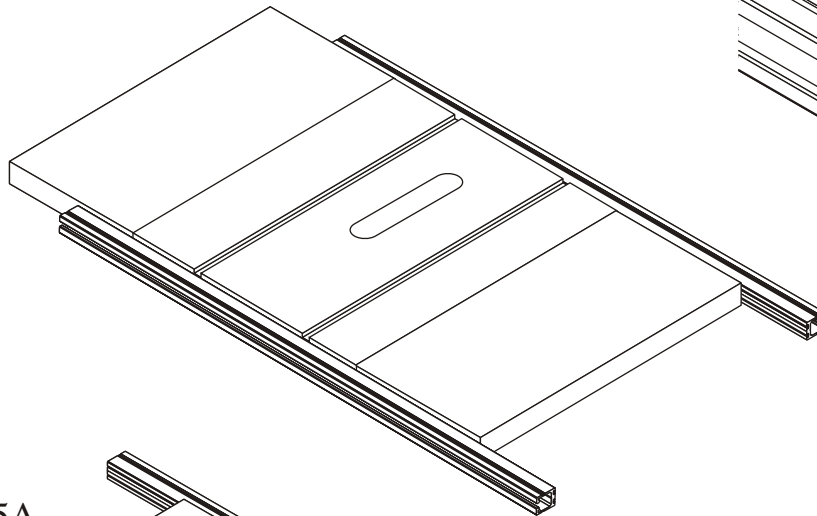
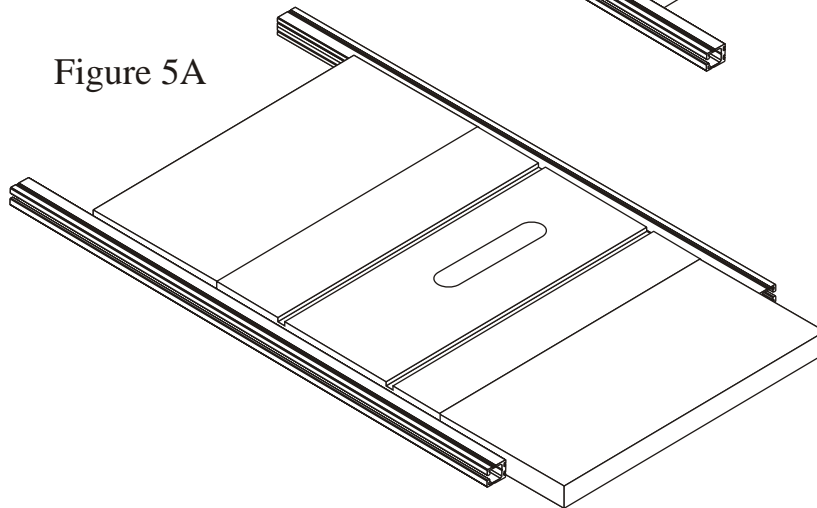

Figure 5A





Installing the Fence Carriage

Step 1

The Fence Carriage (Figure #6) can be installed from either end of infeed side fence guide rail. To install the Fence carriage pull the spring loaded roller (Part #10) back towards the bolt head as you insert the roller in the Fence Rail. (Figure 7). Then guide the Locking Bar into the fence rail opening followed by the second spring loaded roller (be sure that the Locking Bar Guide Bolt (Part # 16) is aligned with the hole in the locking bar) Lock the fence carriage in place by turning locking knob. (Figure 7A)

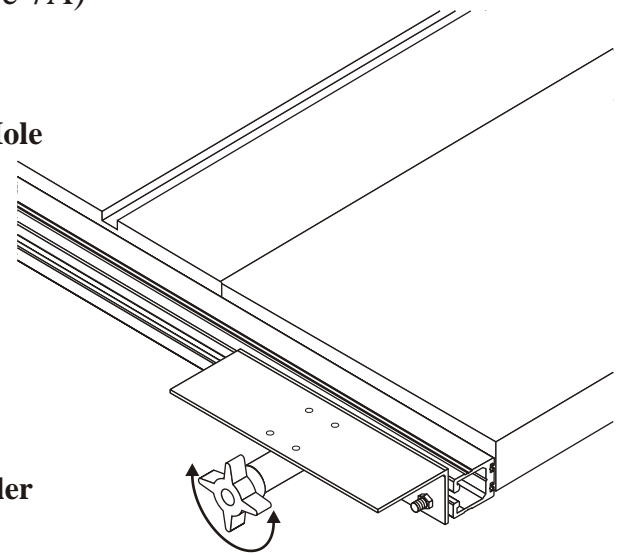
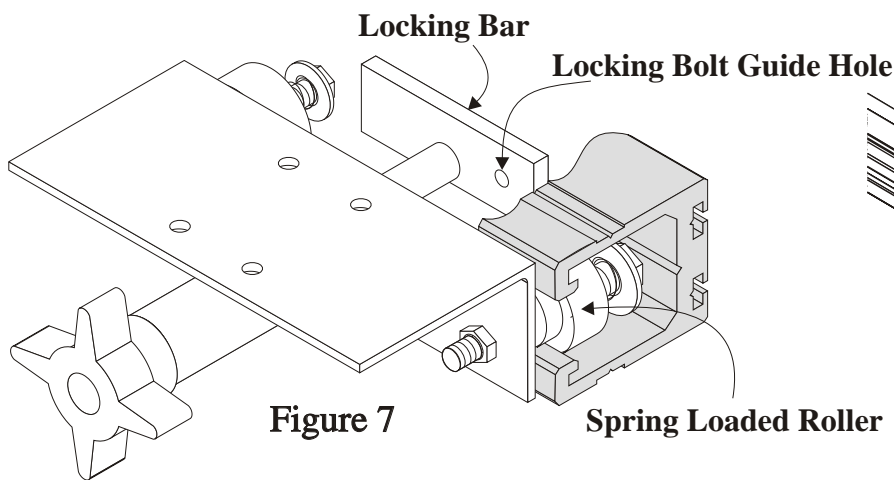
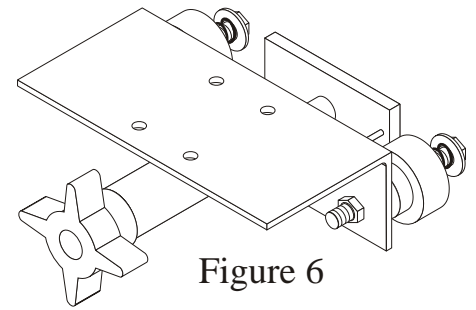

Step 2

Install the Fence Spacer Pad (Part #6) and fence mounting bolts.(Figure 8) Position the Fence Spacer Pad over the four (4) bolt holes in the top of the Fence Carriage, then install the four (4) 1/4" x 20 x 3/4" bolts (Part #9), lock washers (Part #13), and 1/4" lock nuts (Part #12) heads up. Leave the lock nut loose enough so that the fence can be slid onto the bolts (about 3/8" of threads showing)

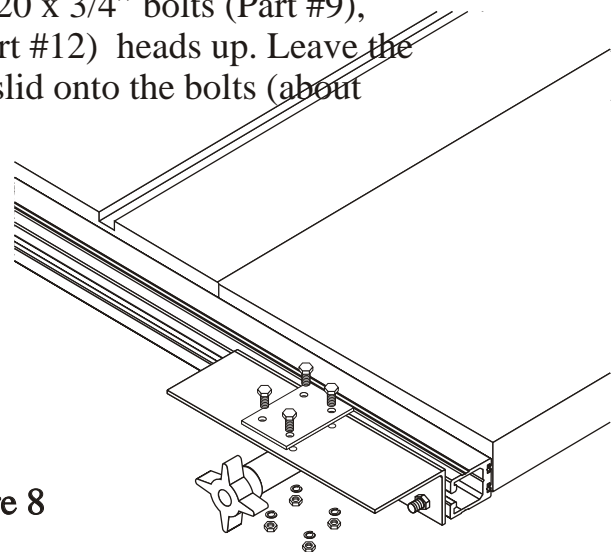



Mounting the Fence To the Carriage

Mount the Fence to the Fence Carriage (Part #3) by first laying the fence on the table top and position the fence so that the t-slots on the bottom edge of the fence align with the four (4) mounting bolts on the Fence Carriage. (Figure 9) Lift the bolts up from the bottom as you slide the Fence onto the four the bolt heads. Position the Fence so that the end of the Fence is even with the edge of the Fence Carriage. (Figure 10 & 11) Snug the four (4) bolts from the bottom so that Fence is just tight enough not to move on the Fence Carriage. You will tighten bolts fully after fence alignment.

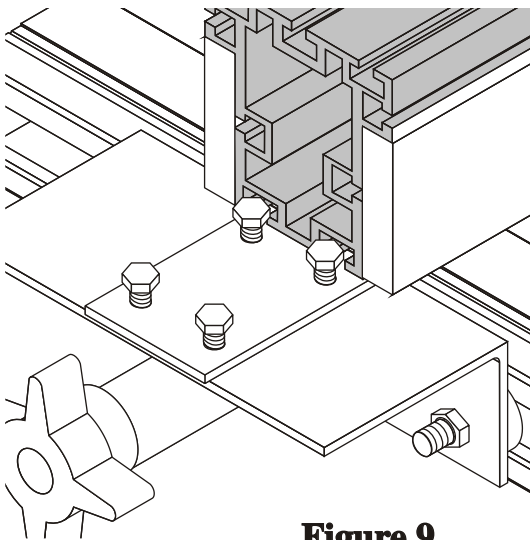

Figure 9

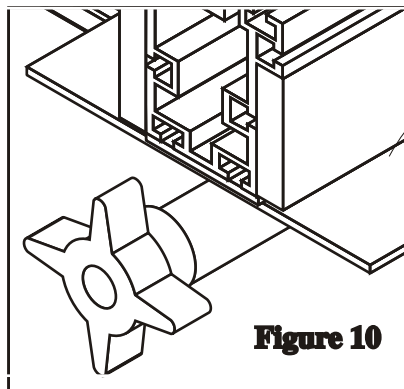

Figure 10

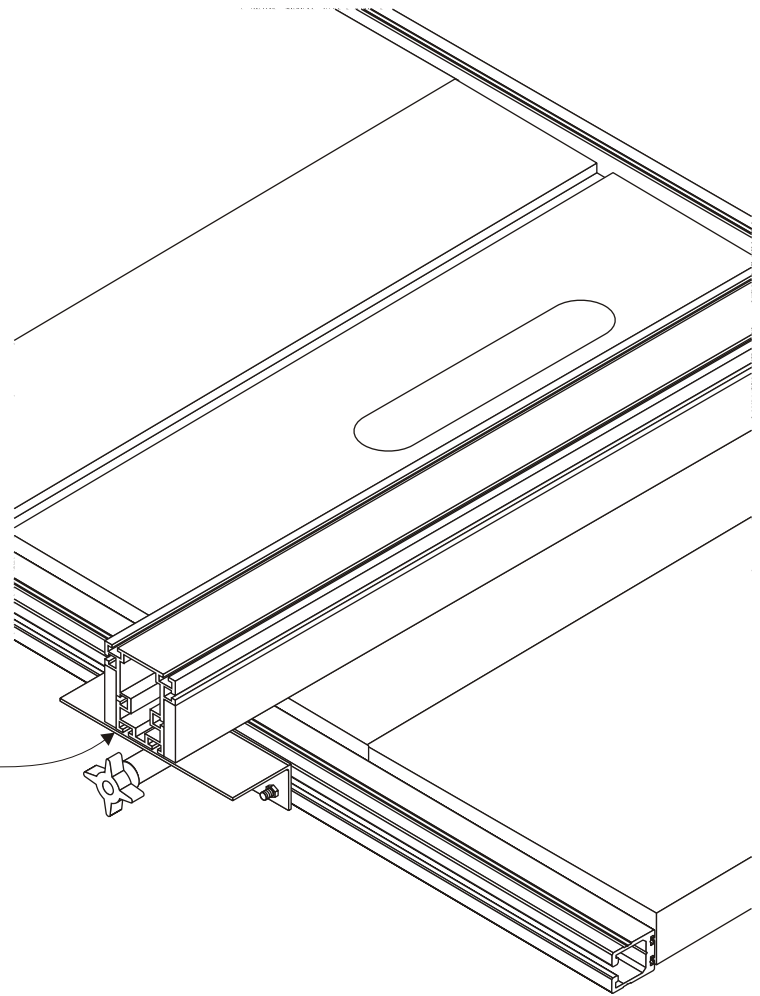

Figure 11



Mounting The Cursor

Step 1

To install the Cursor (Part #17) first remove the Fence and Fence Carriage as one unit by sliding the unit off one end of the Fence Rail.

Step 2

With the two 1/4" x 3/4" Machine Screws and 1/4" nuts installed in the Cursor as shown in (Figure 12) slide the Cursor in the two t-slots in the bottom of the Fence from Tail End (Figure 13). Continue sliding the Cursor down the Fence towards the Fence Carriage. Position the Cursor approximately 3" from the front end of the Fence (Figure 14). Tighten the Cursor in place.

Step 3

Reinstall the Fence and Carriage onto the rails of the table saw.

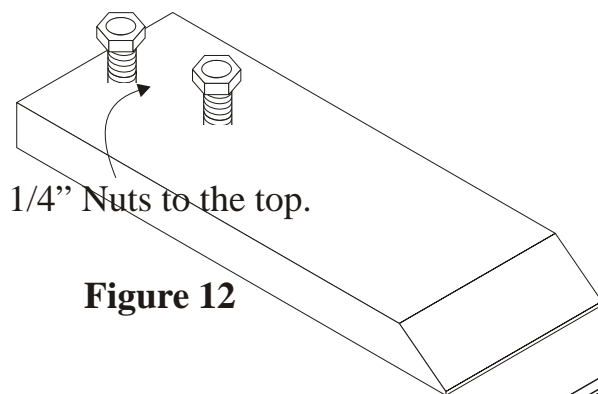

Figure 12

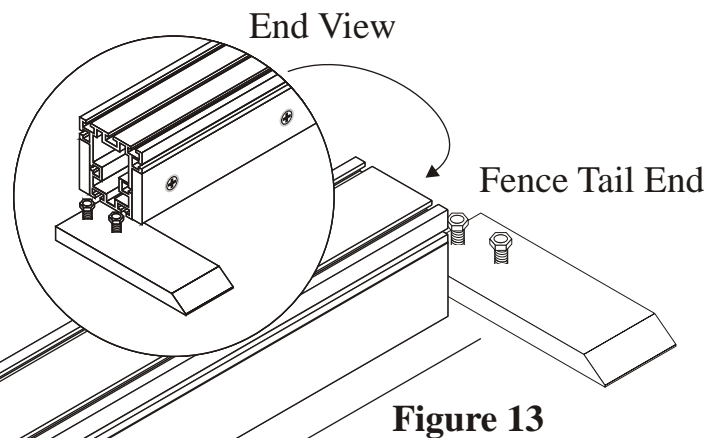

Figure 13

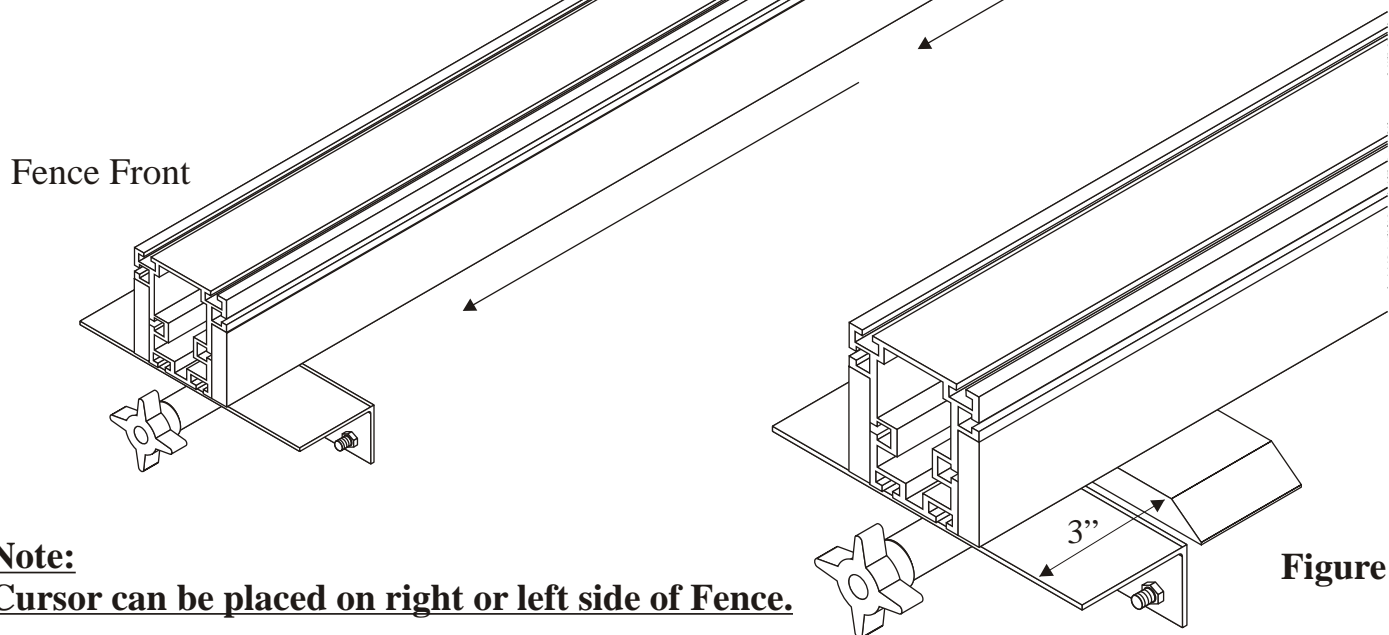

Figure 14

Note:

Cursor can be placed on right or left side of Fence.



Installing the Rear Fence Bracket

Step 1

Assemble the Rear Mounting Bracket as shown in (Figure #15).

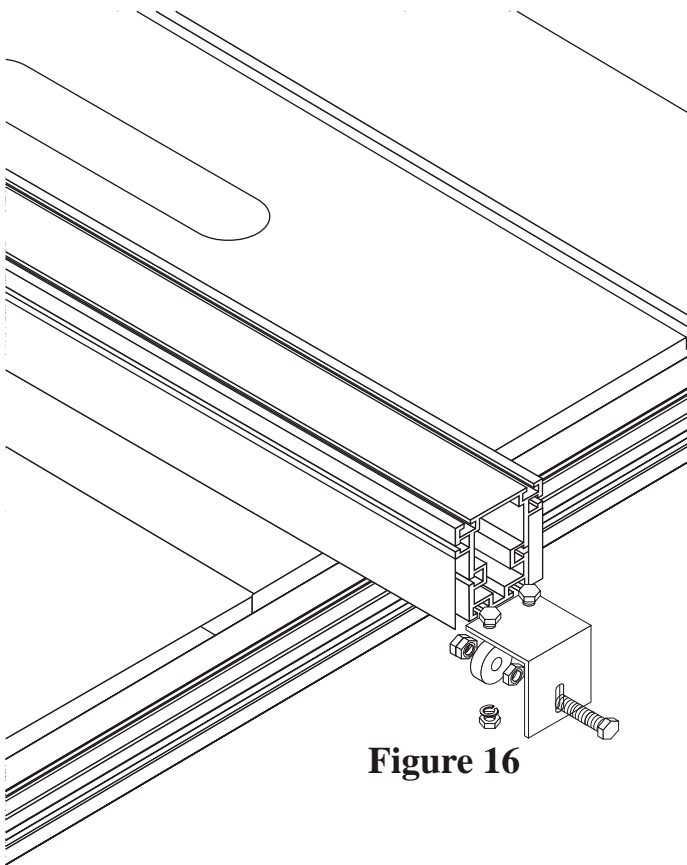
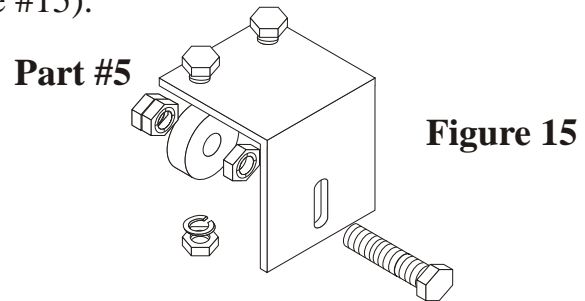

Figure 16

Step 2

Install the Rear Mounting Bracket Assembly (Part # 5) as shown in (Figure 16) by sliding the two mounting bolt heads in the T-tracks on the bottom of the fence then slide the Assembly towards the Rear Fence Guide Rail (Part #2) until the roller is positioned within the Fence Rail as shown in (Figure 17). Adjust the Roller Assembly by losing the 1/4" bolt and nut then position the Roller so that it runs on the flat edge of the fence rail. Tighten the Rear Mounting Bracket Assembly (Part # 5) with the 1/4" nuts under the bottom of the fence.

Step 3

Move the fence both right and left to insure you have smooth operation. If the fence binds adjust the Rear Mounting Bracket (Part # 5) at the location of the bind and recheck the fence movement.

Step 4

Adjust the gap between the table saw top and the bottom of the fence so that it is the same from the front to the back by adjusting the Roller Assembly up or down in the slot of the rear fence bracket.

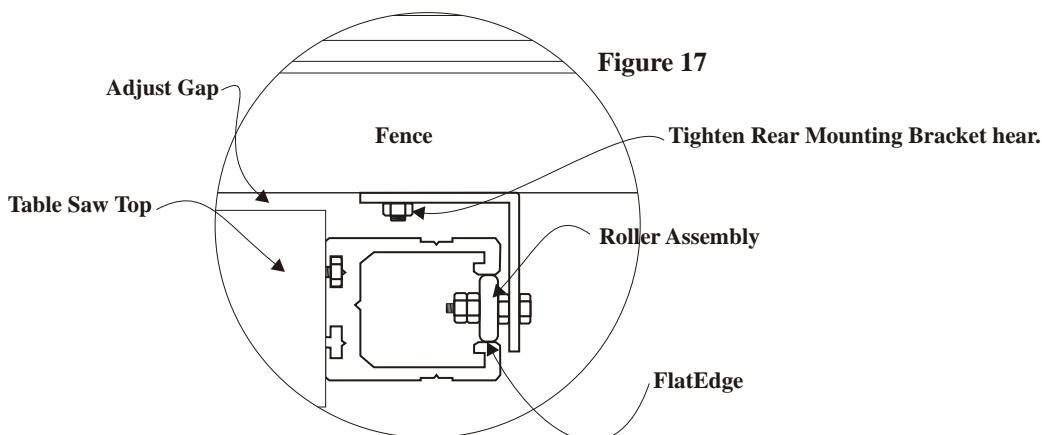

Figure 17





Adjusting Fence Parallelism

Note:

The saw blade to miter slot parallelism must be check and alined per the saw manufactures instructions prior to completing this step.

Adjusting Fence Parallelism

To adust the fence parallel to the table saw miter slot, adjust the fence using the four mounting bolts which mount the fence to the fence mounting bracket (Part #3) in the following manner:

1. Loosen 3 of the four bolts from under the Fence Mounting Bracket (Part #3). By leaving one bolt tight the fence will now pivot on that bolt.
2. Adjust the fence alignment so that the fence is parallel and even with the edge of the miter slot as shown in (Figure 18). Lock carriage onto Fence Rail by tightening Locking Knob (Part #8)

With the Fence aligned to the miter slot tighten all four Fence mount Bolts. Check the fence movement right and left for smooth movement and adjust the rear Fence Mount Bracket as need (see Installing The Rear Fence Bracket Page 9)

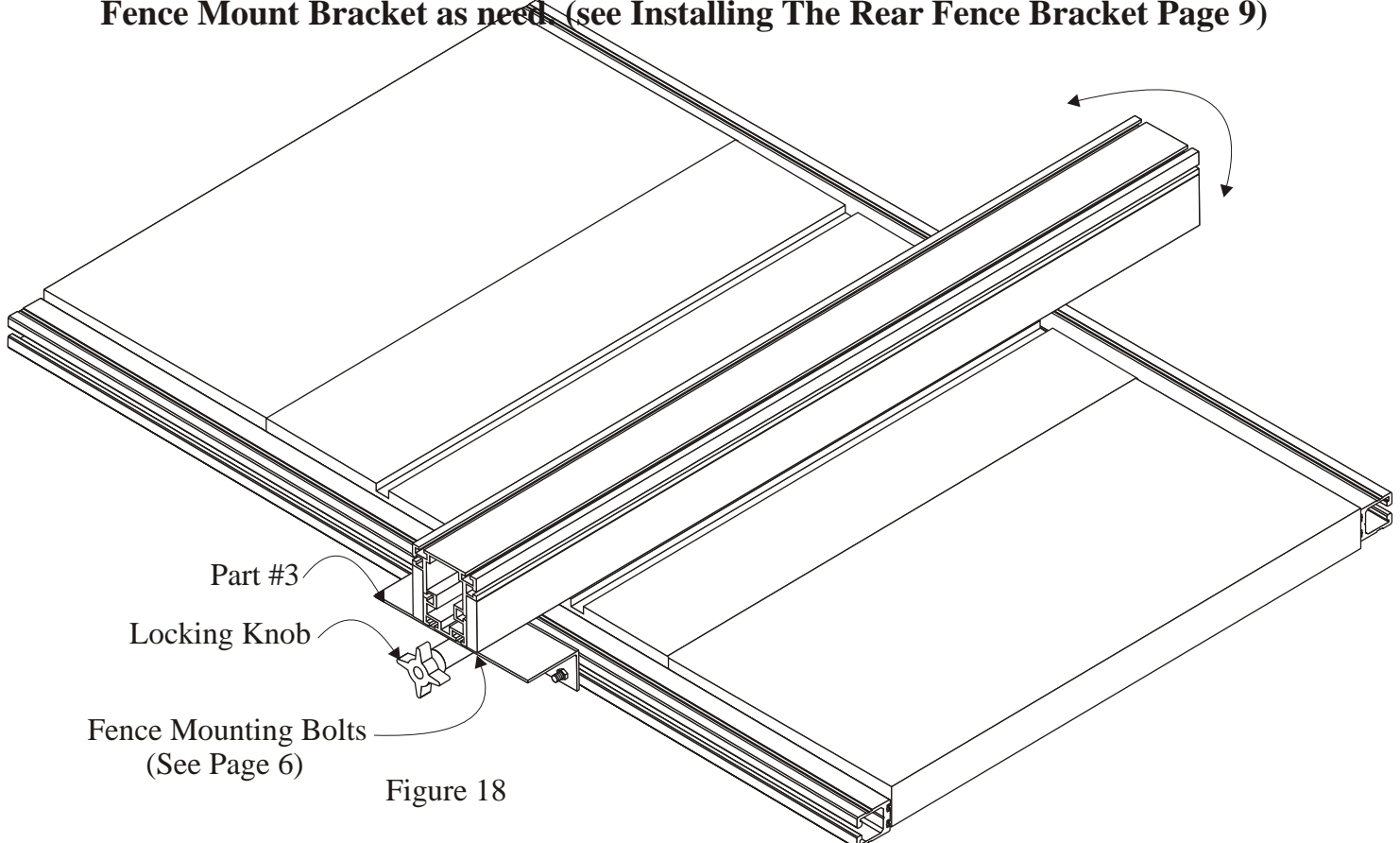



Adjusting the Fence Vertical Square

Adjusting Fence Vertical Square

To adjust the fence vertical square to the saw table shim the fence with thin washers between the Fence bottom and the Fence Spacer (Part #6)

1. Using a square check the fence square as shown in (Figure 19). Shim as needed on the right or left or right hand bolts to bring the Fence square.
2. Check the fence movement right and left for smooth movement and adjust the rear Fence Mount Bracket as need. (see Installing The Rear Fence Bracket Page 9)

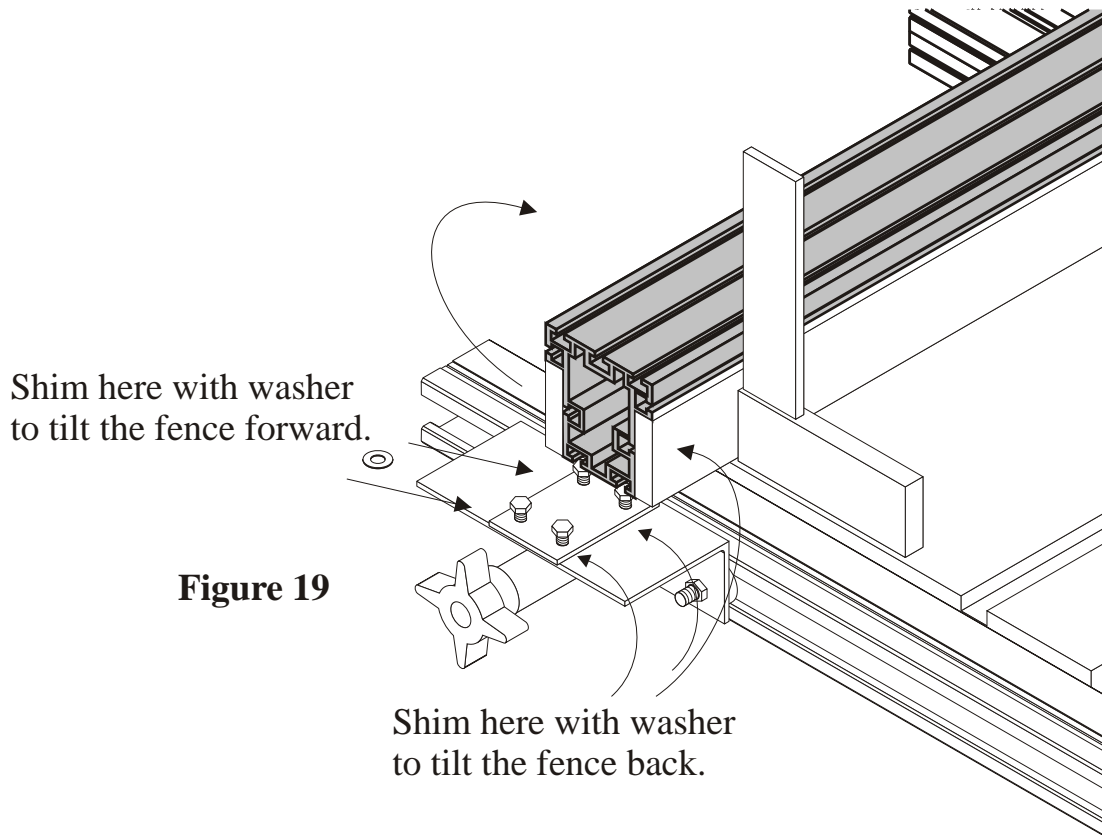



Installing The Tape Measure

WARNING

IMPORTANT NOTE:

Check all the bolts and nuts for proper tightness from the previous Steps before running the table saw.

Step 1

Set the fence away from the saw blade a known distance by measuring from the saw blade to the Fence with a quality rule. (Example 4" Fence to blade)

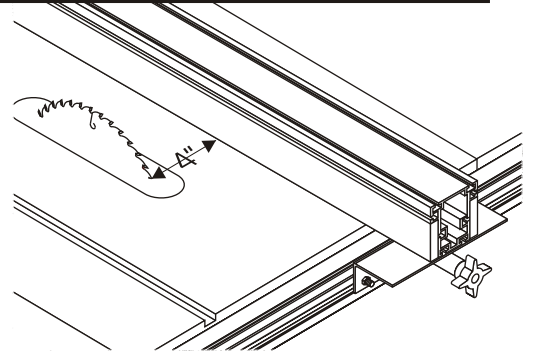

Step 2

Make a test cut using a piece of stock with at least one good straight edge wider than the fence measurement in Step 1. (Example Fence to Blade 4" = stock width of 5") Check the result of the test cut. The test cut must be the exact intended measurement. If the test cut is not the exact measurement reset the Fence and repeat the test cut at a lesser width. (Example Fence to blade 3" = stock width of 4") When the result of the test cut is the exact measured distance from the Fence to the saw blade the Fence Cursor is now set to that measured distance.

Step 3

Place a mark on the fence rail at the edge of where the Cursor will read the tape measure.

Caution: This mark must be straight and as thin as possible. A 5mm pencil or pen is recommended.

Lower the saw blade and move the EZ Square Fence to the left passed the left hand miter slot.

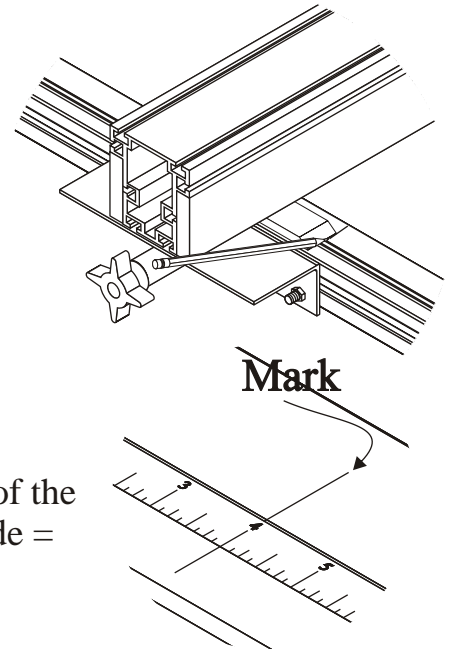

Step 4

Remove the backing from the sticky tape and line up the measurement of the stock you cut to the mark on the Fence Rail (Example 4" Fence to blade = 4" mark on tape measure.) and stick measuring tape to the Fence Rail.

Step 5

Move the Fence Cursor to the same test measurement setting (Example 4") tighten fence at that mark and make a test cut. Compare the two test cut pieces, they should be the exact width.

Note:

To make fine Fence Tape Measure adjustments loosen the Fence Rail mounting bolt nuts slightly and adjust the Fence Rail right or left as need. (Refer to Page 5)