

# Mounting the BGM-100 Set on Your Grinder

The Bench Grinder Mounting Set BGM-100 can be mounted on grinders with wheel diameters from 150 mm (6") to 250 mm (10"). You can either mount the grinder and the BGM-100 on a self made wooden platform or you can mount the grinder and the BGM-100 directly on the bench.

You can mount the BGM-100 set on the left or on the right side of the grinder whichever suits you best. On some grinders, you need to remove the tool rest which comes with the machine, in order to mount the Tormek Universal Support.

You can also mount a set on both sides, which gives you a versatile sharpening station. You can mount the Tool Rest SVD-110 on the second wheel. Thanks to the instant mounting facility of the Tool Rest you can quickly exchange it for the Gouge Jig SVD-185 or for the Multi Jig SVS-50.

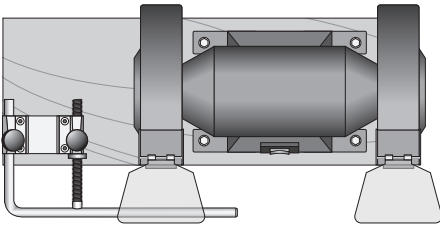

*Left side mount*

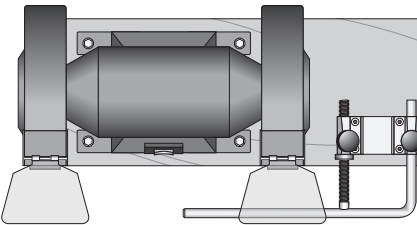

*Right side mount*

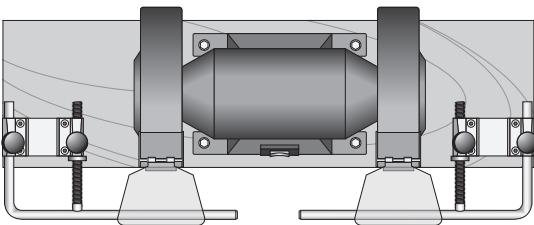

*Mount on both sides*

### Contents: Bench Grinder Mounting Set BGM-100

- Universal Support with Micro Adjust 1 pc
- Base for the Universal Support 1 pc
- Height adjustable block 56–89 mm ( $2\frac{3}{16}$ – $3\frac{1}{2}$ " ) 1 set
- Rubber feet 4 pcs
- BGM-10 Handbook 1 pc
- Profile Labels 1 set
- Bolt M6×12 with nut and washer 4 pcs
- Bolt M5×16 with nut and washer 4 pcs
- Bolt M6×40 with nut and washer 4 pcs

### Making the platform

Use wood or plywood with a minimum thickness of 20 mm ( $\frac{3}{4}$ " ). The dimensions depend upon your grinder, see sketches below.

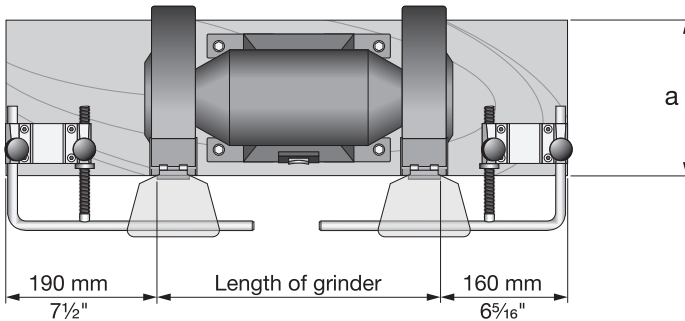

### Dimensions

Grinder size	a	b
150 mm (6")	200 mm (8")	10 mm ( $\frac{3}{8}$ " )
200 mm (8")	200 mm (8")	35 mm ( $1\frac{3}{8}$ " )
250 mm (10")	250 mm (10")	60 mm ( $2\frac{3}{8}$ " )

### Length of platform

This depends on your grinder and if you use one or two BGM-100 sets. The recommended lengths on the left and on the right side differ due to the asymmetrical Gouge Jig SVD-185.

### Height of block

The optimal height of the block depends on the design of your grinder. The best way to make sure the jigs and tools don't hit the guards on your machine is by using the Turning Tool Setter TTS-100 when setting the height. If your grinder needs a block higher than 89 mm ( $3\frac{1}{2}$ " ) place the adjustable block on a piece of wood.

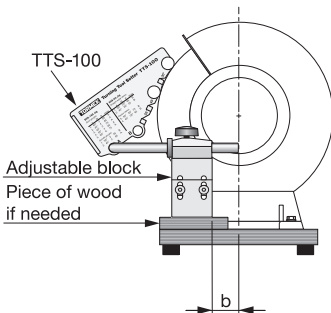

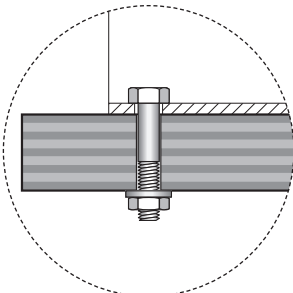
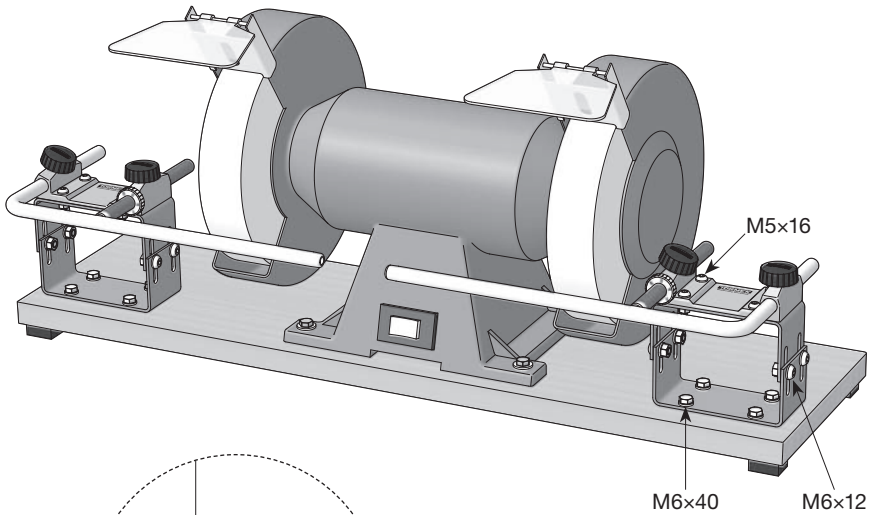

Bolt the block to the platform.

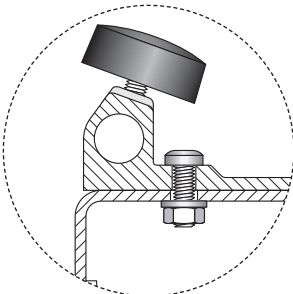

Bolt the base for the Universal Support to the block.

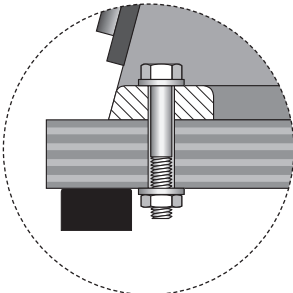

Mount the grinder with suitable bolts, which fit the holes in the grinder. Use washers under the bolt heads and nuts.

Mount the rubber feet and you will get a steady platform with less vibration.