

# Easy Arched Raised Panel Doors

## By: Peachtree Woodworking Supply, Inc.

### Step 1. MAKING A SAMPLE DOOR

- A) This sample door size is 12" wide by 20" long.
- B) The door thickness should be 3/4" - 1 3/16".

### Step 2. DETERMINING THE SIZES OF EACH PART OF THE DOOR

- A) Always use a 1/2" overlay on all sides of the door.
  - B) If door opening is 11" wide by 19" high then the door size is 12" x 20".
- IMPORTANT: Use 2-7/16" wide stiles so the templates will work properly.

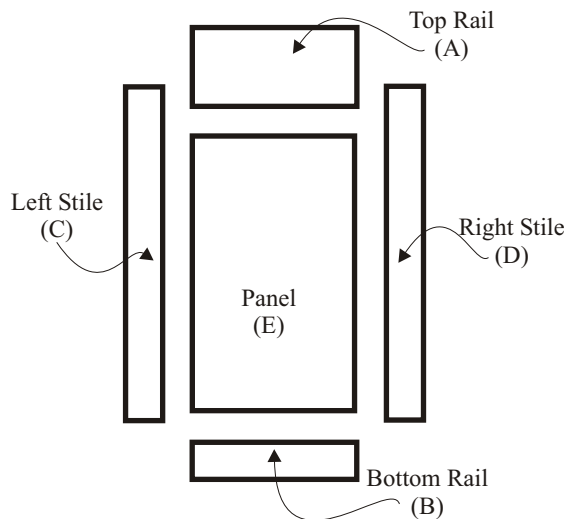

### DETERMINING LEFT AND RIGHT STILES (C) & (D)

- a) Cut stiles 2-7/16" wide.
- b) Length of stiles is same as door length.

### DETERMINING TOP ARCHED RAIL (A)

- 1) Cut 4-1/4" wide. Templates are 4" wide.
- 2) Length of rail is found by subtracting 4" from the total door width. (Overall door width is 12" minus 4" = 8" length of rail) NOTE: This following procedure can only be used when using 2 7/16" wide stiles. Subtract 4" from the total door width instead of 4-7/8" since 7/16" in each stile will be taken up in the pattern cut.

### DETERMINING BOTTOM RAIL (B)

- 1) Cut 2 7/16" wide to match the Stiles.
- 2) Length of rail is again found by subtracting 4" from the total door width. (Overall door width is 12" minus 4" = 8" for bottom rail lengths)

### DETERMINING RAISED PANEL (E)

- 1) Width is always 1/4" less than rail length. (1/8" space should be left on each side for expansion of panel).
- 2) Rail length is 8" minus 1/4" = 7-3/4" width of raised panel.
- 3) Length of Raised Panel is found by taking the overall door length and subtracting 2" for the Bottom Rail and 1 13/16" for the Top Rail when using our Templates for a combined total of 3-3/16" \*\*. This measurement takes account for the pattern cut of 7/16" on each Rail.

Example: Overall door length is 20" minus 3 13/16" = 16 3/16" \*\*

**\*\* Allow 1/8" extra length of Panel to flush trim to Arched Panel Pattern in Step 5.**

### Step 3. CUTTING THE COPE CUTS ON EACH END OF THE 2 RAILS

- A) Cope cutter is the cutter with the bearing in the middle
- B) Set the cope cutter to the correct height in the router.
  - 1) The correct height is when, after the cut is made, the reveal on the front side should be 1/8" minimum (Illustration 1)
  - 2) Spaces A and B shown should be equal. If one is to be bigger, make B thicker for strength of panel.
- C) Set fence even with bearing.
- D) Use wooden push-block to prevent tearout at end of cope cut.
- E) Run stock through with good side down at 10,000 - 12,000 RPMs.

Illustration 1

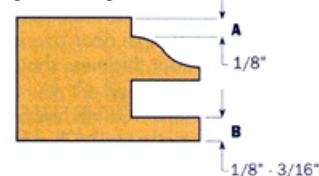

### Step 4. USING RAIL TEMPLATE TO FLUSH TRIM TOP RAIL TO CORRECT SHAPE

- A) Locate center of top rail with pencil on the backside.
- B) Pick out the correct template.

**NOTE:** THE SIZE ON THE TEMPLATE IS FOR THE OVERALL DOOR WIDTH. FOR THE TEMPLATES TO WORK PROPERLY STILES MUST BE MADE 2 7/16" WIDE. IF STILES ARE MADE IN DIFFERENT WIDTHS, ADJUSTMENTS IN PICKING OUT TEMPLATES MUST BE MADE.

- C) Line up template on backside of rail centering the notch of template with centerline of rail. Now nail through the template into the 2 copes that were just cut (Illustration 2).

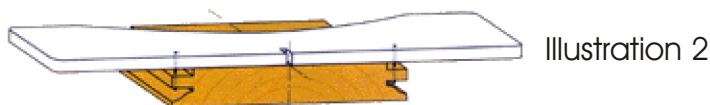

Illustration 2

- D) Rough cut with jig or band saw within 1/8" or 1/4" of template (Illustration 3)

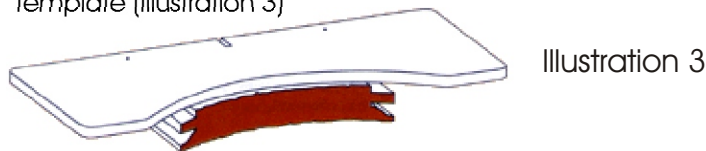
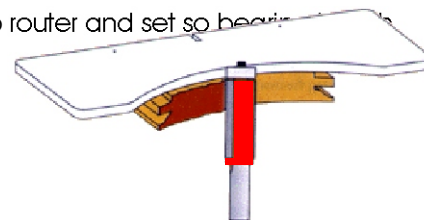

Illustration 3

- E) Put flush trimming bit into router and set so bearing with template (Illustration 4)

Illustration 4



- F) Run router at 14,000-16,000 RPMs and flush trim top crown rail with good side down.

**NOTE:** WHEN STARTING CUT, ALWAYS REMEMBER TO MAKE CONTACT WITH BEARING TO A PLACE ON THE TEMPLATE WHERE THERE IS NO WOOD TO PREVENT KICKBACK.

- G) Slow down at end of cut to prevent tearout. Leave

**Step 5. USING PANEL TEMPLATE TO FLUSH TRIM THE RAISED PANEL TO SHAPE**

- A) Locate and mark the center line of raised panel on front side.
- B) Measure up from the bottom edge of the Panel Blank and place a mark on the center line at the finished Panel length. This is the measurement from Step 2 for the Panel length.
- C) Pick out correct template (same size as rail template).
- D) Line up center notch of template with center line of panel and top edge of template at the finished Panel length mark. Make sure it is also square (Illustration 5).

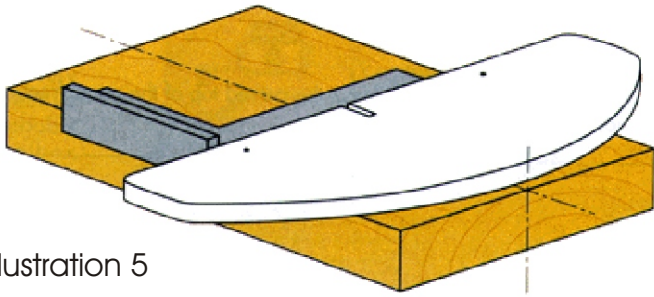

Illustration 5

**NOTE:** DRIVE NAILS IN ABOUT 1/4"-3/8". THE NAIL HOLES WILL BE MACHINED OUT WHEN RAISED PANEL CUT IS MADE.

- E) Rough cut stock to within 1/8" of template.
- F) Flush trim raised panel in the same manner as you did the top rail with the template on top (Back to illustration 4).

**NOTE:** AGAIN MAKE SURE BEARING COMES IN CONTACT WITH TEMPLATE FIRST AND THEN GUIDE INTO THE WOOD.

- G) Pull nails out after flush trimmed.

**Step 6. CUTTING FREEHAND PATTERN CUT ON TOP ARCHED RAIL**

- A) Pattern cutter is the cutter with the bearing on top.
- B) Insert pattern cutting bit to correct height to match cope cut. This can be done by making a few practice cuts in scrap wood.
- C) Run router at 10,000 - 12,000 RPMs.
- D) Start cut with bearing making contact with template only and ease into cut. No fence is used. (Illustration 6).
- E) Slow down at end of cut to prevent any chipout.
- F) Remove template from top arched rail. **Step 7. CUTTING THE STRAIGHT BOTTOM RAIL AND 2 STILES**

- A) Insert fence and line up fence with bearing on the same pattern cutter.
- B) Run router 10,000 - 12,000 RPMs.
- C) Use push-block and push bottom rail through with good side down.

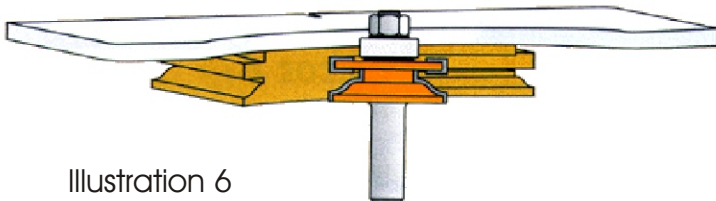

Illustration 6

**Step 8. MAKING RAISED PANEL CUT**

- A) Insert panel cutter to correct height

**NOTE:** IT MAY TAKE A COUPLE OF PRACTICE CUTS IN SCRAP WOOD BEFORE GETTING THE PANEL FLUSH WITH PATTERN CUT.

- B) Set fence so it is even with bearing on panel cutter.
- C) Run router slow 8,000-9,000 RPMs. ALWAYS USE PUSH BLOCKS FOR SAFETY.
- D) Make first cut across the grain with good side face down.
- E) Cut with the grain on left side.
- F) Remove fence and use a half-fence. (Illustration 7)
- G) Start by re-doing left side and come around and cut the curved top of the panel freehand.
- H) Install full fence and complete right side.

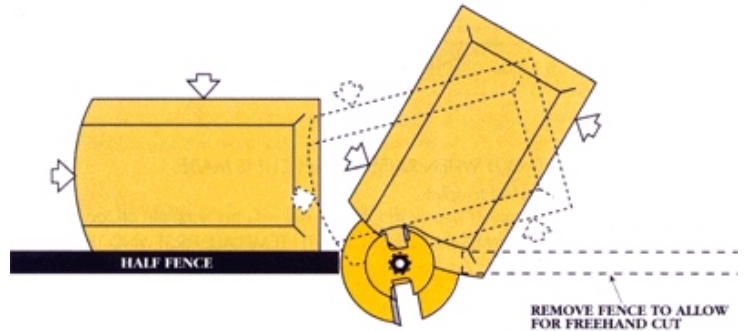

Illustration 7

**Step 9. FINISHING**

- A) Sand all pieces where needed, insert Panelign Strips (see catalogue page 12), and glue up. Do not glue raised panel itself, only cope cuts and where they meet the pattern cuts.
- B) After the door is sanded, use the door edger bit for a professional looking edge treatment. (Illustration 8)
- C) For mini-raised panel cut on the drawers, use the drawer front bit. (Illustration 9)

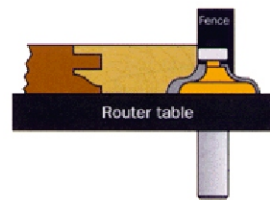

Illustration 8

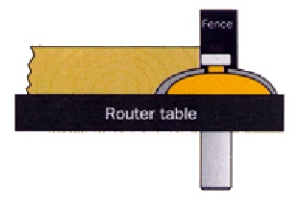

Illustration 9

**Visit us Online at:**

[www.ptreeusa.com](http://www.ptreeusa.com) - [www.ttrackusa.com](http://www.ttrackusa.com) - [www.justfreud.com](http://www.justfreud.com) - [www.justclamps.com](http://www.justclamps.com) - [www.nosawdust.com](http://www.nosawdust.com) - [www.allsawblades.com](http://www.allsawblades.com)