

Two Methods of Vise Installation

Side View - Flush Mount

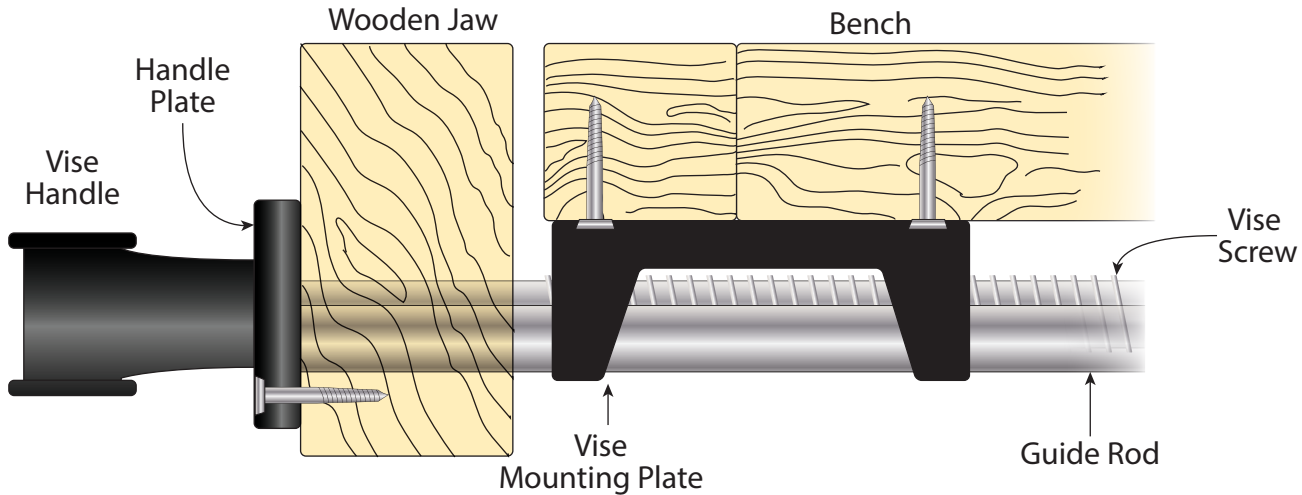

Drill three holes on the wooden jaw. It is recommended that you do this on a drill press to keep the holes square with the face of the wooden jaw. The holes should be slightly larger than the diameters of the vise screw and guide rods.

Remove the Vise Mounting Plate from the vise screw and guide rods. (for quick release vise disassembly, see *Quick Release Vise Drawing*) Slide the guide rod and vise screw through the holes you drilled in the wooden jaw. Secure the handle plate onto the wooden jaw with wood screws (screw size and length may vary depending upon the size of your vise or wooden jaw). Slide the vise mounting plate back over the vise screw and guide rods and mount the vise mounting plate to the underside of the bench (screw size and length may vary depending upon the size of your vise or thickness of your bench). Keep the vise mounting plate approx. 1/32" from the edge so it doesn't interfere while clamping.

Side View - Offset Mount

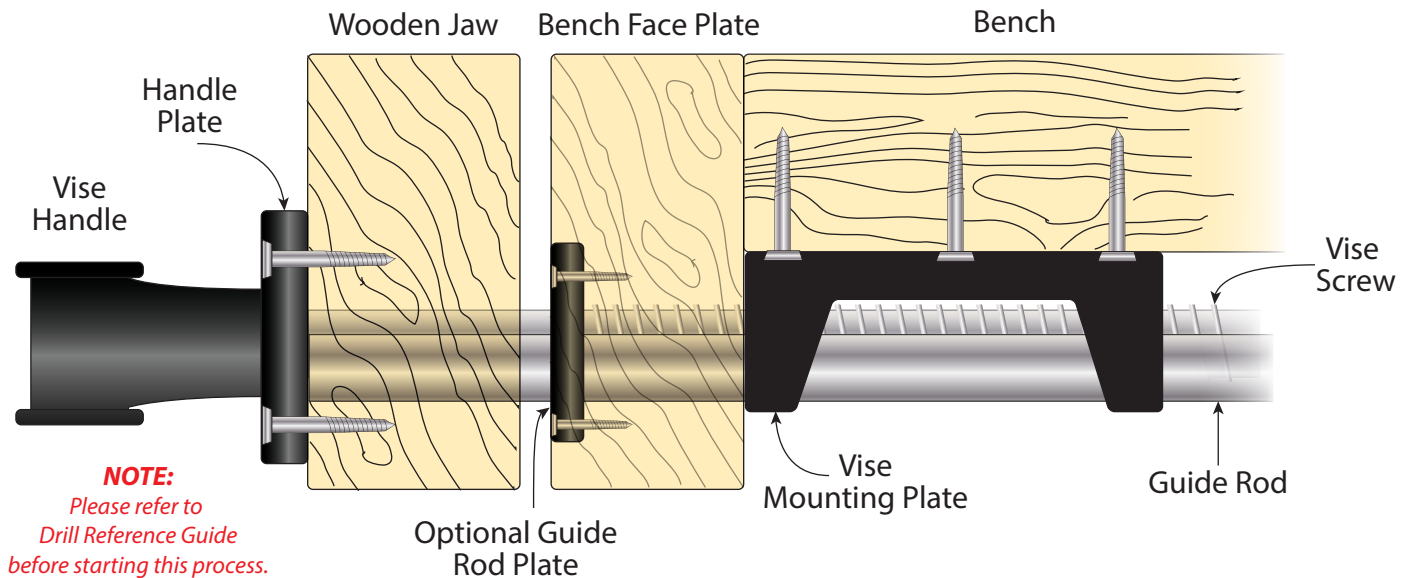

Measure from the top of the vise mounting plate to the center of the vise screw and drill the hole for the vise screw in the bench face plate. Measure from the top of the vise mounting plate to the center of the guide rods and drill two holes for the guide rods in the bench face plate. Drill three matching holes on the wooden jaw inline with the holes on the bench face plate. It is recommended that you do this on a drill press to keep the holes square with the face of the bench face plate. The holes should be slightly larger than the diameters of the vise screw and guide rods. *Note: some vises come with guide rod plates for added stability, the guide rod plate must be inlayed into the bench face plate and secured as shown above.* Remove the Vise Mounting Plate from the vise screw and guide rods. (for quick release vise disassembly, see *Quick Release Vise Drawing*) Slide the guide rod and vise screw through the holes you drilled in the wooden jaw. Secure the handle plate onto the wooden jaw with wood screws (screw size and length may vary depending upon the size of your vise or wooden jaw). Slide the vise screw and guide rod through the holes on the bench face plate and onto the vise mounting plate and mount the vise mounting plate to the underside of the bench. See diagram above (screw size & length may vary depending upon the size of your vise or thickness of your bench).

Drill Reference Guide for Offset Mount

Please Note: Hole size and locations will vary depending upon which vise and how thick your workbench is.

Drilled View Wood Jaw

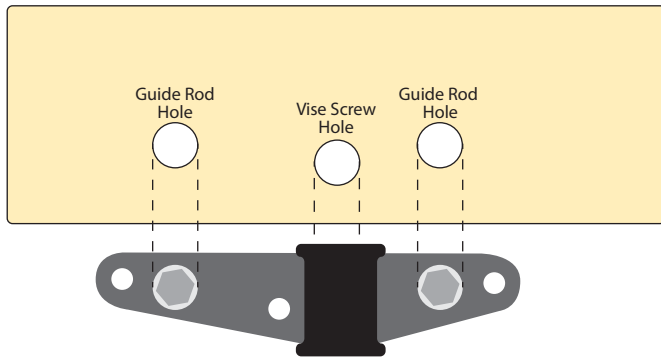

Drilled View Bench Face



When drilling the holes of your wooden jaw or bench face plate be sure that each hole is slightly larger in diameter than the Vise Screw and Guide Rods. It is recommended to use a drill press for this to keep the holes aligned and square to the face. This keeps the vise from binding while installing and while using the vise. Depending upon which vise you selected, the spacing and the diameter of the holes will vary. When laying the holes on the bench face plate, this measurement will also vary depending upon how thick your workbench top is. We start this layout by measuring the distance from the vise mounting plate to the center of the vise screw and guide rods. Next, measure from the top edge of the bench face plate to the bottom edge of the work bench. Mark the distance from that line to the measurement you acquired from the top edge of the vise mounting plate to the center of the vise screw and guide rod. Note: you can trace a pattern of the vice handle plate onto a piece of cardboard and use that as a template for even better accuracy.



CAUTION:

If your guide rod / vise screw holes are not properly aligned with the vise mounting plate or are not drilled square to your bench face it may cause racking or binding of the components. This may result in damaging the vise mounting plate which is not covered by warranty.

Quick Release Vise

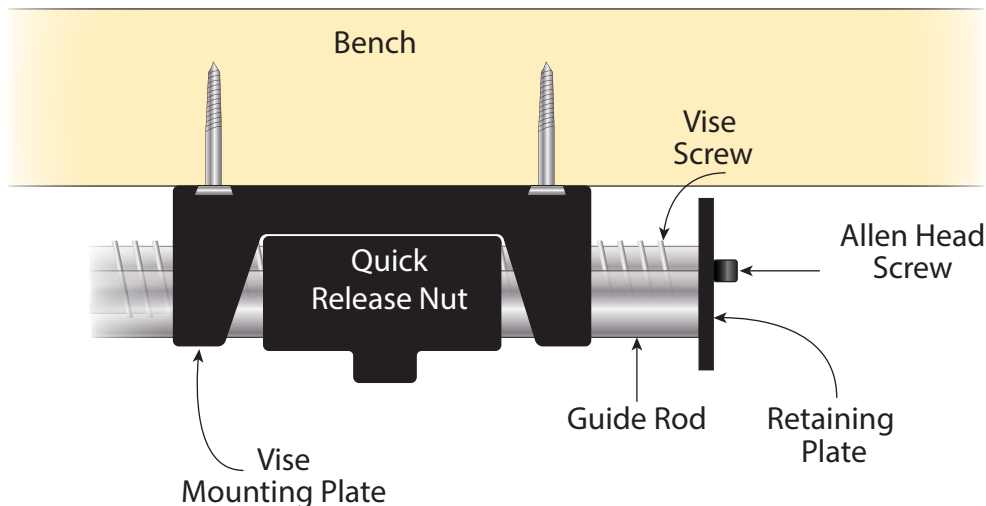

Quick Release Disassembly

In order to remove the vise screw and guide rod from the vise mounting plate, you must first remove the allen head screw and retaining plate. Be sure to note the position of the quick release nut components on the screw. They must be mounted the exact same way when re-assembling your vise onto your workbench.

General Vise Maintenance

It's a good idea to perform general maintenance on your vise. Depending how often you use your vise will determine how much you should clean it and perform any kind of maintenance.

- Remove the jaw assembly including the guide rods and vise screw from the workbench.
- Clean out any dust and debris using a brush or air hose.
- Clean any grease or old lubricant from the vise using soap and warm water.
- Dry all of the parts of the vise thoroughly.
- Re-lubricate the vise using a light grease on the Guide rods and vise screw and lightly oil the rest of the vise.
- Install and re-assemble the vise.
- Oiling vise will prevent rust formation.