



Mounting & Balancing Grinding Wheels

Be sure to read, follow and understand your machine or power tools instruction and safety procedures before proceeding. Always wear proper safety equipment, and unplug any machine or power tool before making any adjustments.

General Guidelines for mounting a Grinding Wheel

For your grinding wheel to work and function correctly, it is important that your wheel is properly mounted and aligned. If your wheel is out of balance or mounted incorrectly, it may wobble. This may create an improper grinding surface and may also cause injury.

By reading and performing the following steps in these instructions, you will be able to correctly mount and align your grinding wheel.

Installation of your Grinding Wheel

Slide the grinding wheel onto the grinder arbor. The wheel should fit tightly on to the arbor. If you feel any “play”, place masking tape around the arbor until the wheel fits properly. Secure the wheel in place with the steel washer and arbor nut. Using a pencil, label the wheel left and right side respectively as shown in **Figure 1**.

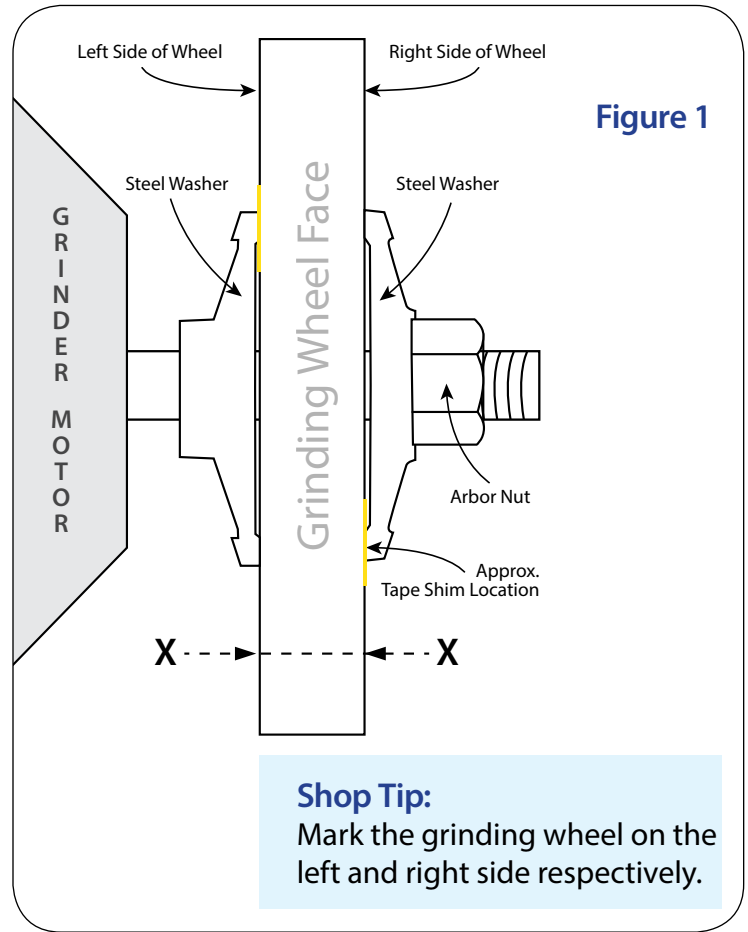

Aligning the Grinding Wheel

Prior to finishing the grinding wheel installation process, the wheel must be correctly aligned with the grinder so that it runs true during operation.

With the wheel on the grinder arbor (be sure to leave wheel housing and guard off during this process), slowly rotate the wheel by hand. As you are rotating the wheel, look for the furthest point that the wheel moves to the right. Mark that point on the right side of the wheel with an “x” on the wheel. Mark another “x” on the left side of the wheel at the approximate same location as shown in **Figure 2**.

Remove the arbor nut, washer and wheel from the grinder.

In this step we are going to use masking tape to act as a shim that will balance the wheel. Place a piece of masking tape on the right side of the wheel as shown in **Figure 2**. The tape should be placed on the paper washer so it lines up with the “x” mark on the right side of the wheel and it also falls underneath the steel washer once secured.

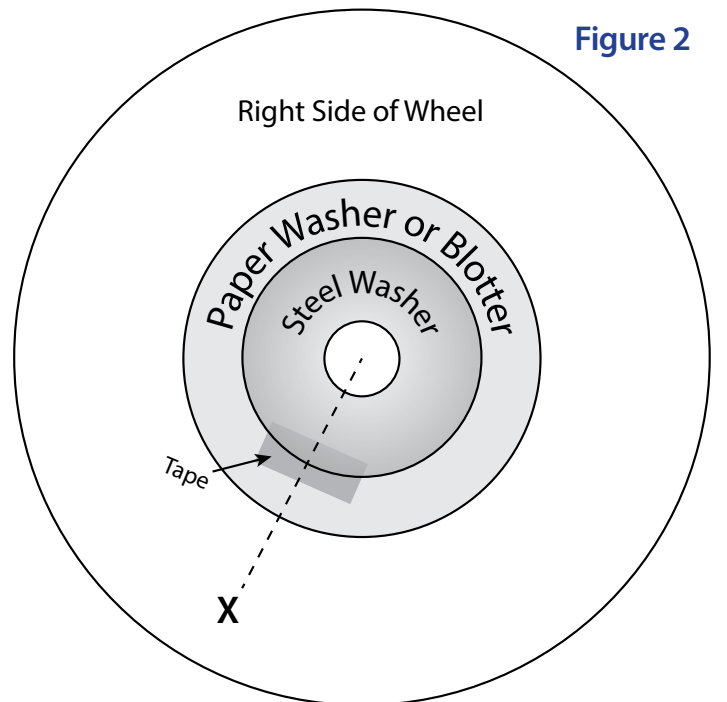

Place a piece of masking tape on the Left side of the wheel as shown in **Figure 3**. The tape in this instance should be placed on the opposite side of the arbor hole and the "X" on the left side of the wheel as shown in **Figure 3**. Make sure the tape falls underneath the steel washer once secured.

Reinstall the wheel, steel washer and arbor nut back on to the grinder and secure the wheel. Check the wheel again by rotating the wheel as previously done in these instructions. If adjustments need to be made, add more tape strips until the wheel runs true.

The face of the wheel may be slightly off after balancing the wheel. If this is the case, read and follow the instructions below for dressing the grinding wheel.

Dressing your Grinding Wheel

Before dressing your grinding wheel, make sure the housing, guard and tool rest are in place and are not interfering or obstructing the grinding wheel.

Please be sure to wear safety glasses and or face shield when running your grinder. Plug the grinder in, power it on and wait for it to come up to speed.

Place a diamond wheel dresser tool on to the tool rest and gradually work it into the face of the grinding wheel. Keep the face of the diamond dresser flat against the face of the grinding wheel while moving it side to side.

Continue dressing the grinding wheel until the face of the wheel is flat and running true.

Caution:

Do NOT push into the grinding to forcefully with the diamond dresser. Doing so may cause uneven spots which could also change the shape of the wheel.

Repeat this entire process for the other wheel on your grinder for optimum results.

Figure 3

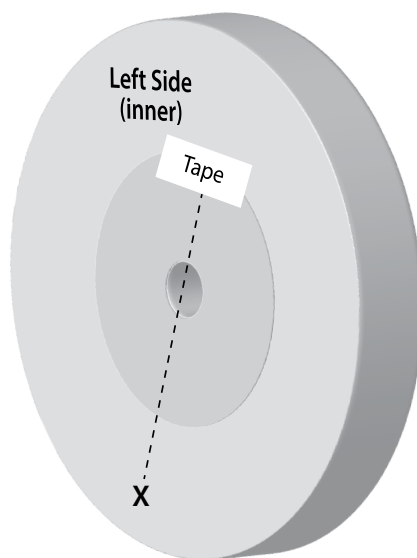

Shop Tip:

Note the different position of the tape in reference to the "X" mark.

Figure 4

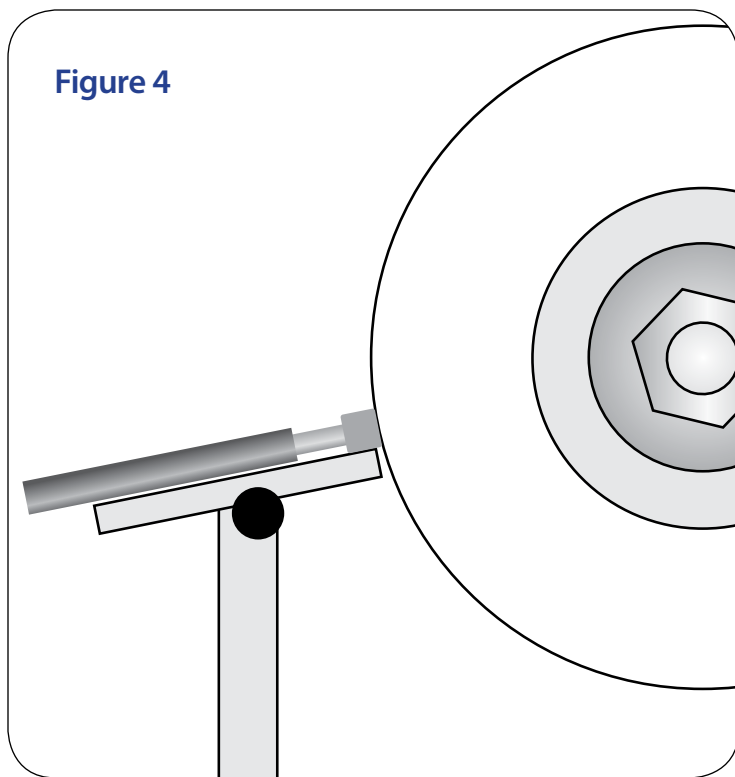

Shop Tip:

Work the diamond dresser gradually into the wheel, do not force it.