

Panel Max XL Glue Press Instructions

Gluing up panels of stock has never been easier than with the Panel Max Glue Press system! Unlike pipe or bar clamps which tend to overtighten and sometimes misshape your stock, the Panel Max applies pressure on all four sides of the work piece, ensuring a flat uniform surface every time.

CAUTION: Make sure the power supply is disconnected on your power tool(s) or machinery before making any adjustments. Don't use any tools with out the proper safety guard(s) in place or without reading the instruction manual that came with the unit. Always wear the proper eye, ear and respiratory equipment when using power tools.



Before Assembly of The Panel Max Can Begin...

1. **Cut a piece of lumber** - that is 4" x 3" and at least as long as the Panel Max Slide Rail.
2. **Cut a piece of lumber** - that is 4" x 2½" and at least as long as the Panel Max Slide Rail.
3. **Mount the 4" x 3" piece** - to the base of your wall, making sure the piece is positioned parallel to the floor.
4. **Mount the 4" x 2½" piece** - to your wall 52" on center from the floor. This will provide a stable surface to mount the Panel Max Slide rail.
5. **Attach the Slide Rail** - to 4" x 3" piece of stock (top piece) using 3 wood screws.

Assembly of The Panel Max

Figure A

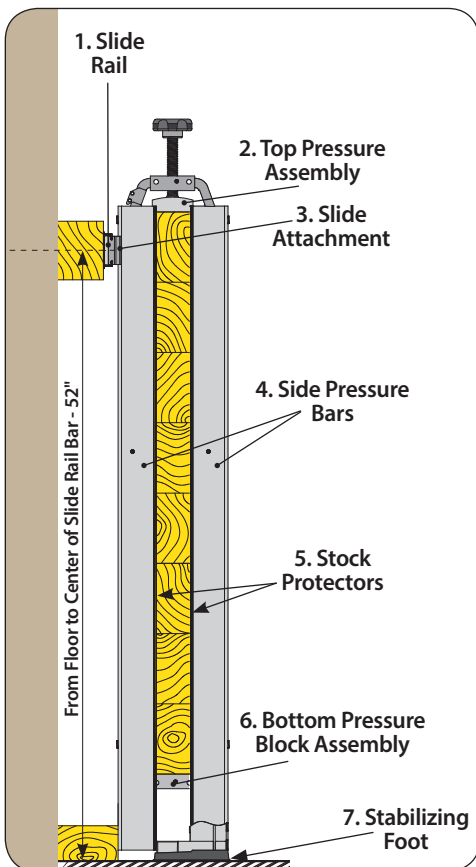

1. **Attach the stock protectors** on to the side pressure bars as shown in Figure A
2. **Screw the Slide attachment (3)** onto the side pressure bar(s) from the inside of the bar as shown if Fig. A1. *Note: the Slide attachment should be in the second square hole from the top of the Side Pressure Bar.*
3. **Attach the Stabilizing Foot (7)** in the bottom of the Side Pressure Bar as shown if Figure A2. Place the second Side Pressure Bar into the Stabilizing Foot with the tapered end Facing the first Side Pressure Bar.
4. **Insert the Bottom Pressure Block Assembly** between the Side Pressure Bars as shown in Figure A3.
5. **Install the Top Pressure Assembly** into the two Side Pressure Bars from the top side as shown in Figure A4. The Plastic Fitting is designed to support the Assembly when placing wooden boards into the glue press.

Fig. A1

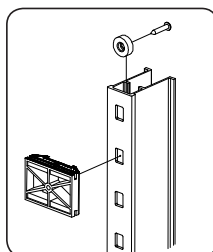

Fig. A2

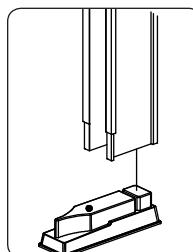

Fig. A3

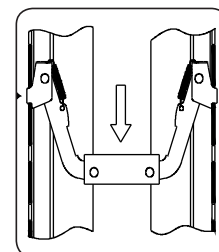
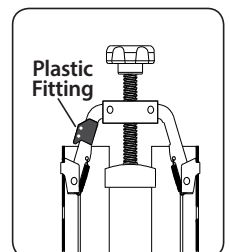
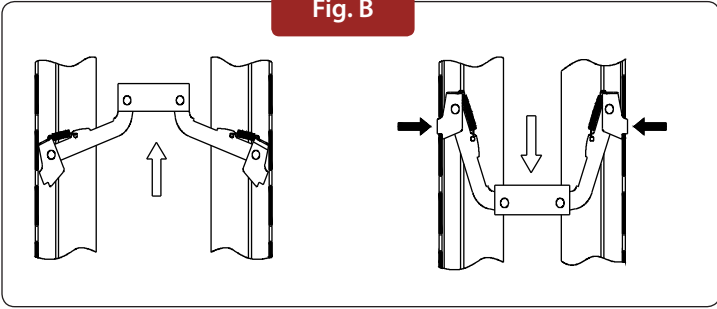

Fig. A4



General Usage of The Panel Max System

Fig. B



- **The stop** on the Top Pressure assembly can be adjusted to any desired height depending on the width of your stock to be glued.
- **Insert** the wooden boards one piece at a time. Once all your pieces are in the glue press and the bottom stop is set to the correct height, secure the wood pieces by turning the knob on the Top Pressure Assembly.

Fig. C

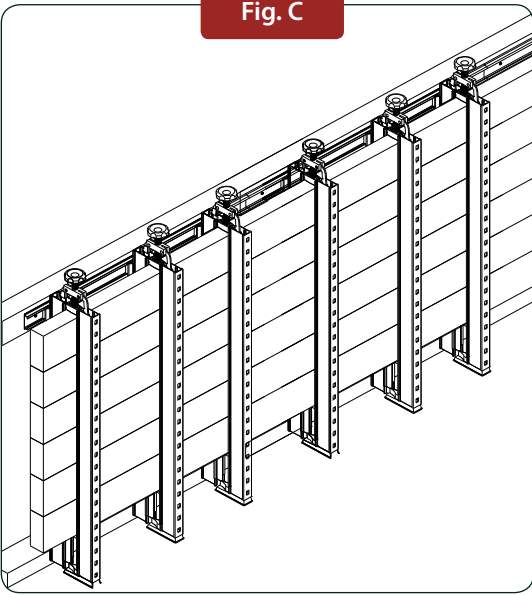

- **Expandable** - You can attach as many Slide Rail's side by side to achieve any length needed. Extra Rails and Side Pressure Bars are available for purchase.

General Panel Max System Maintenance

- When not in use, push the Side Pressure Bars together to avoid accidentally bumping into them.
- The threads on the Top Pressure Assembly should be lightly greased from time to time.
- Do your best to keep any glue from getting on any of the Panel Max Parts. If glue does get on the Panel Max System, clean the glue off as soon as possible.

Technical Specs

- Stock Thickness (in between Side Pressure Elements)0" to 5" thick.
- Actual Gluing Height (panel height).....44" to 50"
- Approximate Gluing or Clamping Pressure.....1725 lbs