

Assembly Instructions

T-Bar Modular Tool Rest System

ITEMS REQUIRED:

A T-Bar or a Bowl Rest of your choice and a 5/8", 3/4", 7/8", 25mm, 1", 1-1/8", 30mm, 1-1/4" or a 1-1/2" diameter Post.

TOOLS REQUIRED:

One wrench as shown in the chart below:

Post Size	Wrench Size
5/8" Dia.	11/2" Wrench
3/4" Dia.	5/8" Wrench
7/8" Dia.	3/4" Wrench
1" Dia. & 25mm	7/8" Wrench
1-1/8" Dia.	1" Wrench
1-1/4" Dia. & 30mm	1-1/8" Wrench
1-1/2" Dia.	1-3/8" Wrench

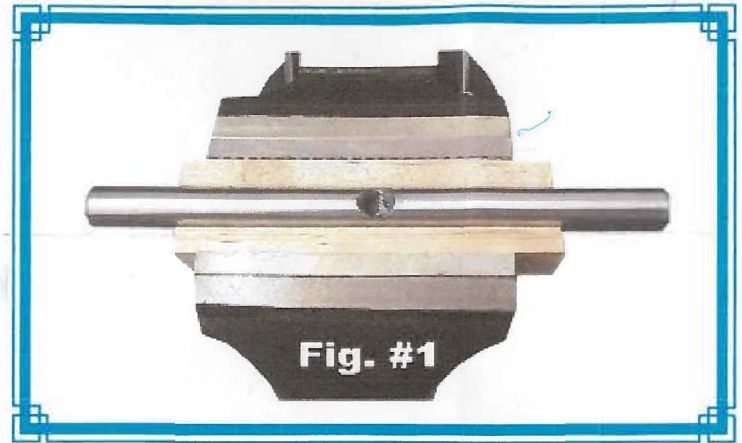

STEP#1:

Place the T-Bar or Bowl Rest (tapped hole facing up) into a vise, or other suitable work holding device, lined with wood or soft plastic strips to prevent any marring of the T-Bar as shown in Fig. #1.

STEP#2

Place the Brass Trim Ring onto the T-Bar and align with the tapped hole in the T-Bar. Screw the Post you have chosen through the Brass Trim Ring and into the T-Bar, being careful not to cross the threads. **Do not use the Brass Trim Ring supplied with each post with the Adjustable Bowl Rest System, use the Flat Brass Washer instead. The Reversible Bowl Rest System does not use either the Brass Trim Ring or the Brass Washer.** Tighten finger tight while keeping the Brass trim ring seated on the T-Bar as shown in Fig. #2. Important! Make sure the Post is finger tight at this point of the assembly.

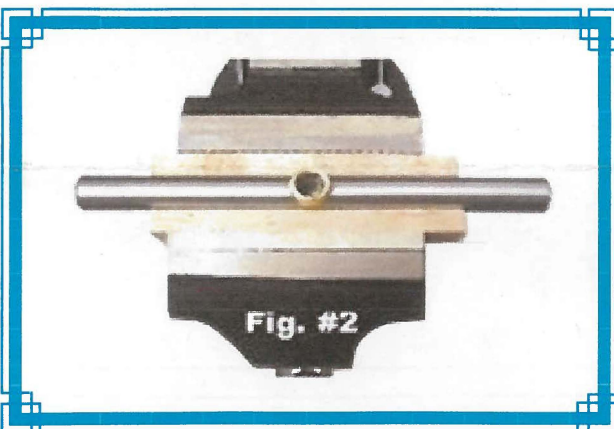

STEP#3

Tighten the Post into the T-Bar or Bowl Rest using the appropriate wrench, as shown in the above chart.

CAUTION!! Damage to the threads can occur if you over tighten. We recommend tightening the Post 1/8 turn from the finger tight position.

IMPORTANT: If you have any sharp edged tools, (on the back of the tool) that rests on the tool rest, you need to sand or grind the sharp edge smooth.

CARE & MAINTENANCE: To protect your investment and insure many years of use, the T-Bar System should be protected from the environment with a good coat of paste wax. If storing for long periods of time, coat the entire surface with a rust preventative such as oil or a product like WD-40.