

Quick^{PLAN}

Downdraft Box

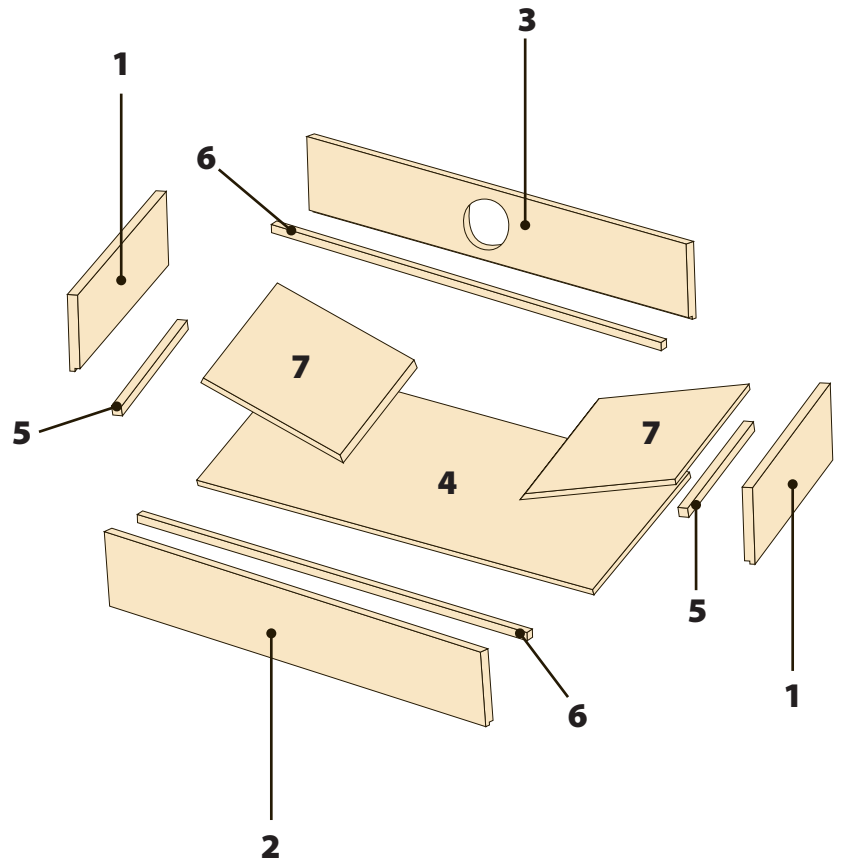

Materials Needed

- 1 Sides $6\frac{3}{4}'' \times 17\frac{1}{2}'' \times \frac{1}{2}''$ (2 pieces)
 - 2 Front $6\frac{3}{4}'' \times 27\frac{1}{2}'' \times \frac{1}{2}''$
 - 3 Back $6\frac{3}{4}'' \times 27\frac{1}{2}'' \times \frac{1}{2}''$
 - 4 Bottom $17'' \times 27\frac{1}{2}'' \times \frac{1}{2}''$
 - 5 Side Support Bars $\frac{3}{4}'' \times 15\frac{1}{2}'' \times \frac{1}{2}''$ (2 pieces)
 - 6 Front and Back Support Bars $\frac{3}{4}'' \times 27'' \times \frac{1}{2}''$ (2 pieces)
 - 7 Dust Collection Fall-off Ramps $12'' \times 16\frac{1}{2}'' \times \frac{1}{2}''$ (2 pieces)
- Downdraft panels (3592) available in sets of two.

Instructions:

The box shown above is made of laminated MDF, you can of course use whatever material you choose. In making the box you can use glue with screws or nails to secure the butt type joints.

1. Cut each number piece to size as shown in the material list above.
2. Cut a $\frac{1}{4}''$ deep x $\frac{1}{2}''$ high rabbet on the bottom edge of parts **1, 2 & 3**.
3. Cut a 4" diameter hole in part **3**. The hole should be $13\frac{1}{2}''$ (on center) from the sides and 4" (on center) from the top of part number **3**.
4. Use glue and either screws or nails to assemble and fasten the main body of the dust panel box (parts **1, 2 & 3**).
5. Attach the bottom (**4**) with either screws or nails.
6. Attach all support bars (parts **5 & 6**) $\frac{7}{8}''$ down (height of the steel dust panels) from the top of the box using glue and nails or screws. The downdraft panels rest on these supports.
7. Cut the long edges of the dust run-off ramps (**7**) to 45° and 20° respectively. Meaning - one end should be at 45° and the other end should be at 20°
9. Attach the ramps (**7**) with the 20° edge directly under the side support bars and the 45° end resting on the center of the box bottom (**4**).
10. Attach a 4" blast gate on the back side of panel **3**.
11. If not laminated, use the finish of your choice to achieve the look you desire.