







Package Contents:

-  **A** GRP-41 Heel Spacer x 2
-  **B** GRP-42 3/4" Gravity Heel for Table Saw x 2
(Drop Range 0 - 3/4")
-  **C** GRP-43 1" Gravity Heel for Coping on Router Tables x 3
(Drop Range 0 - 1")
-  **D** GR-H13 1/4-20 Thumb Knob x 2
-  **E** GR-H14 Shoulder Washer x 2
-  **F** TJ-H2 Compression Spring x 2
-  **G** GR-H12 1/4-20 X 1 3/4" T-Bolt x 2

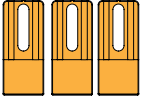
Installation:

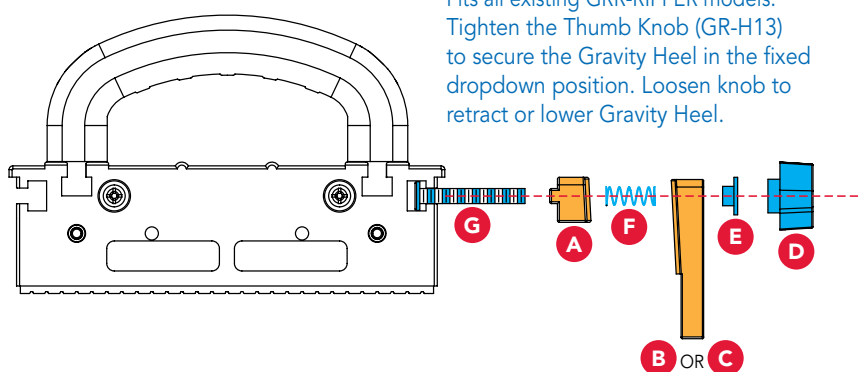

Using the Gravity Heel:

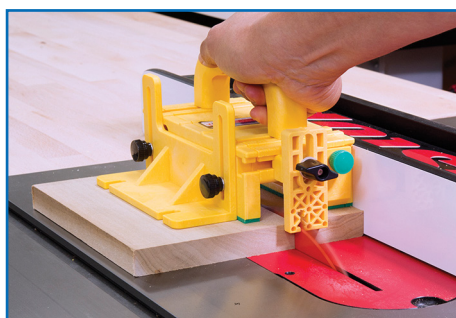

Figure 1

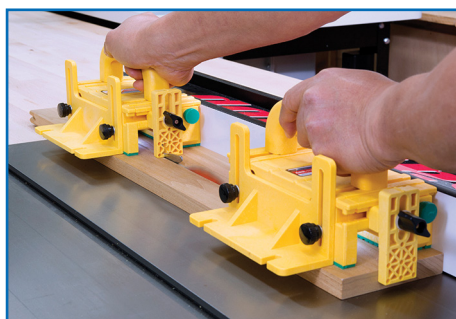

Figure 2

1. Set the Gravity Heel so that it lays on top of the workpiece.
2. Lightly tighten the knob (GR-H13) and loosen a half-turn.

This will place the Gravity Heel approximately 1/4" below the threshold of the stock. See Figure 1.
WARNING! Do not begin cut or turn on table saw until properly set.
3. While the Gravity Heel is in this position the GRR-RIPPERS are attuned for the hand-over-hand (leapfrogging) method for long stock ripping. See Figure 2.

NOTE: The Gravity Heel will automatically drop to a 1/4" below threshold at the end of the stock and automatically retract when placed mid-board.

4. The Gravity Heel is meant to be cut through and is replaceable.
5. Use as a back stop during coping operations on a router table to prevent blow out on the workpiece.

NOTE: The Inclined mating surfaces of the Heel Spacer and the Gravity Heel control how far the heel drops, the more the knob is loosened, the further it is lowered.

Download a PDF version of these instructions at
MICROJIG.com/grghmanual