

# 50 Cal Bolt Action Pen Kit

## Kit Features:

- Available with solid tip or DIY turned tip
- Uses an authentic 50 cal cartridge
- Minimum parts - easy to assemble
- Available in multiple finishes
- Overall Length: 5-3/4"
- Uses Parker® Style refill
- Tube sizes: 8mm & 3/8"

## Required Accessories:

- 7mm Pen Mandrel
- Drill Bit(s): 8mm, 3/8"
- Bushing set (3 pc): PK50BABU
- Barrel Trimming set: 8mm & 3/8" (From PKTRIMKIT) Solid tip style
- Live Tailstock Center
- 2 Part Epoxy Glue or Insta Cure (Cyanoacrylate) Glue
- Pen Blank: Minimum Size - 7/8" x 1-3/4" Long (Metal Tip)  
7/8" x 2-1/2" Long (Wood Tip)



## DIAGRAM A / PARTS LAYOUT

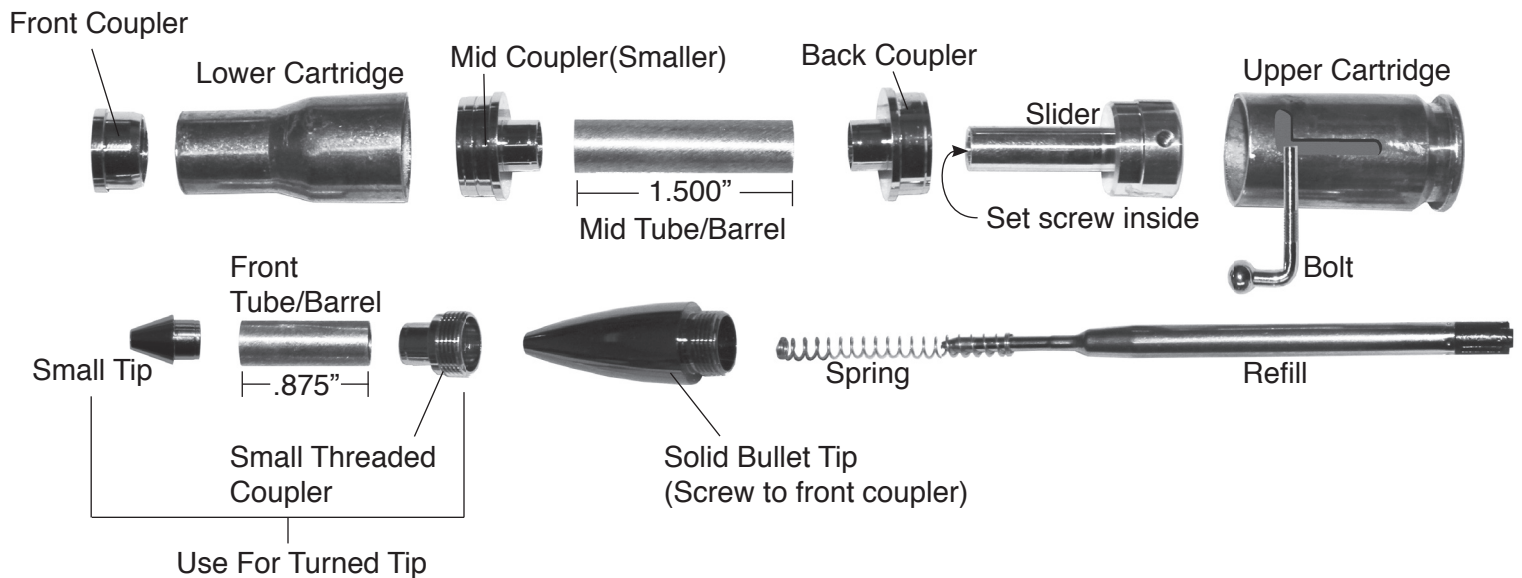

## Preparing the Blank: *(NOTE for Solid Tip - Use instructions for 3/8" tube only)*

- Cut blank(s) to the length of the tubes and add 1/16" for squaring off.
- Drill 8mm & 3/8" holes lengthwise through the blanks.
- Spread glue over the tubes, insert the blanks with a twisting motion to spread the glue evenly inside.
- Center the tubes lengthwise inside the blanks.
- When the glue is dry, square the ends of the blanks. Use a 8mm & 3/8" barrel trimmers, or a universal pen blank squaring jig with a power disc sander. Take the excess material down flush with the ends of the brass tube. (do not trim beyond the length of the tube since this may interfere with operation of the mechanism and assembly). Use a barrel trimmer to clean the inside of the tube.

## DIAGRAM B / TURNING THE BLANKS

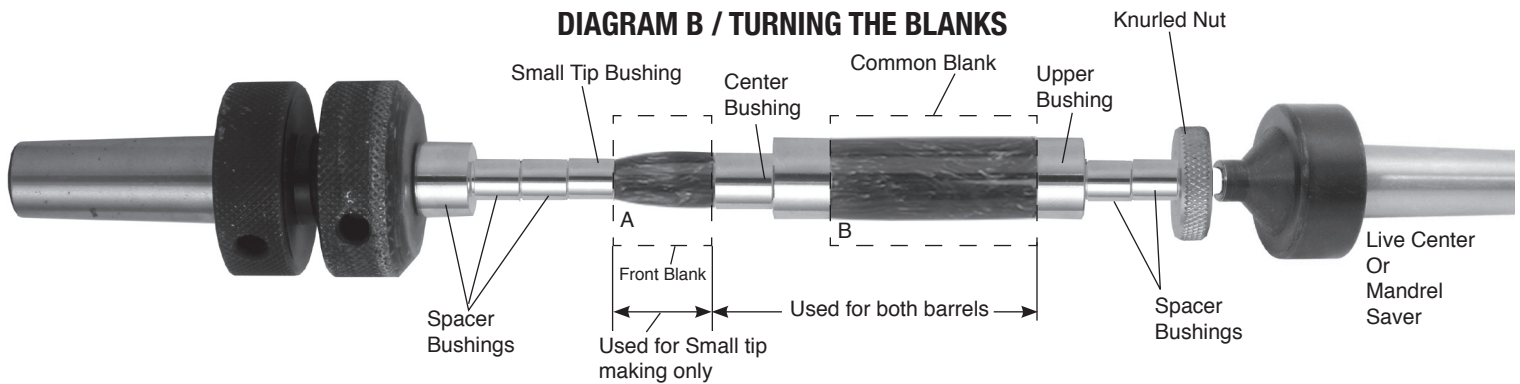
**Turning the Blank** (If making turned tip - refer to turned tip assembly)

- Mount the bushings and blanks according to diagram B.
- Thread on the knurled nut and hand tighten to hold all components in place.
- Slide the tailstock up snugly against the mandrel shaft inserting the live center point into the mandrel dimple, lock in place.
- Hand tighten the quill adjustment to firm up the mandrel. (DO NOT overtighten, it could damage the mandrel.)
- Using sharp tools, turn the blank down close to the bushing diameter. Turn the barrel (straight or to a profile of your choice)
- Sand the blank(s) down to be flush with the bushings gradually increasing the sandpaper grits.
- Finish the barrel(s) with your choice of polish. Allow sufficient time for the polish to cure. Refer to polish instructions.
- (A) Use setup when turning tip.
- (B) Use set up when making either barrel.

**Assembly**

- Layout parts according to diagram A

**For pens with turned tips or bullet tip:**

- Press the front coupler into the small opening of the lower cartridge.
- Press the mid barrel, narrow end in first into the projection of the mid coupler.
- Press the mid coupler (small dia.) into the opposite end.
- Press the back coupler into the opposite wider end of the barrel.

**For turned tip only:**

- Press the small tip into the narrow end of the front barrel.
- Press the small threaded coupler into the opposite end of the front barrel.

**For both styles:**

- Insert the slider wide diameter in first into the opening at the upper cartridge. Locate the threaded hole at the large diameter. When located, insert the bolt. Thread through the slot down to the bottom. Adjust the bolt such that the ball is at a 90° to the upper cartridge. Use a thin phillips screw driver through the slider tube and tighten the set screw to secure the bolt in place.
- Slide this assembly through the back coupler. Press the back assembly/upper cartridge onto the back coupler.
- Affix the spring over the refill, drop the refill into the opening.
- Screw the tip/tip assembly into the front coupler.
- To operate the pen, press down with your thumb on the bolt into the bay for use.

**Diagram C / Bushings #PK50BABU**