

Keychain Pen w/ Stylus Kit

PKTS100 • PKTS101 • PKTS102

Kit Features:

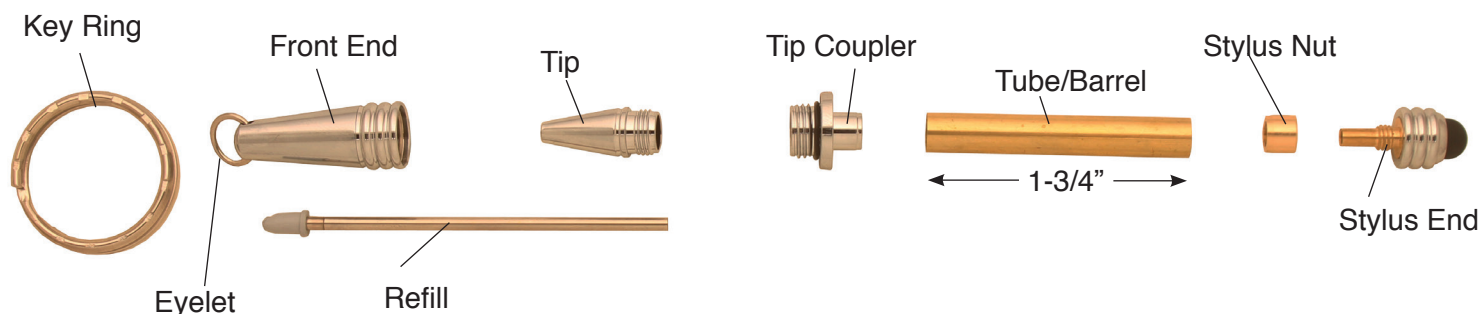
- Easy to turn with a straight tube
- Minimum parts - easy to assemble
- Available in multiple finishes
- Uses mini refill #PKMINI-R5
- Overall Length: 3-3/8"

Required Accessories:

- 7mm Pen Mandrel
- Drill Bit: 7mm #PK-7MM
- PKTS100BU Bushing set(2 pc)
- PKTRIM7 Barrel Trimming set
- Live Tailstock Center
- 2 Part Epoxy Glue or Insta Cure (Cyanoacrylate) Glue
- Pen Blank: Minimum Size- 5/8" x 2" L

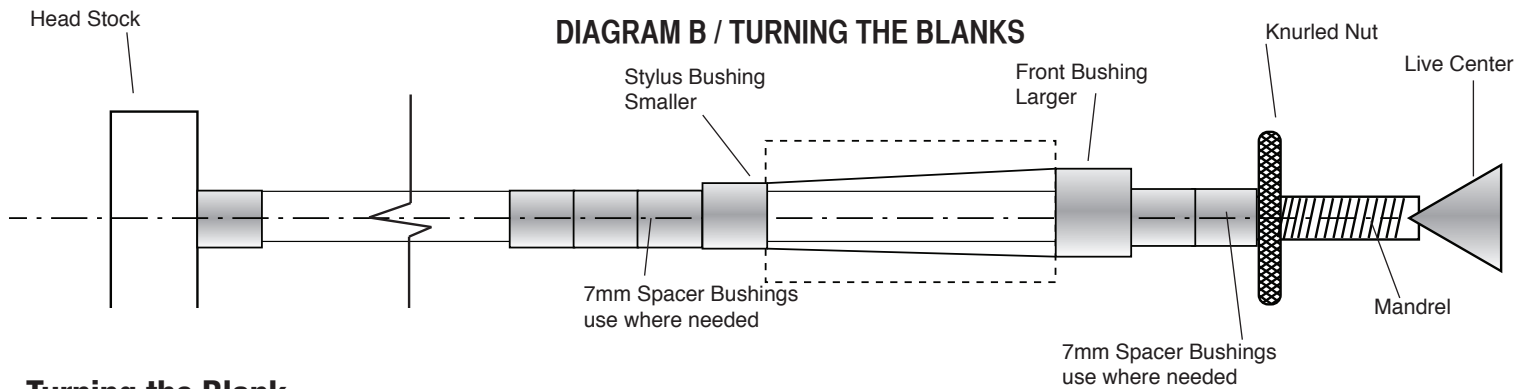


DIAGRAM A / PARTS LAYOUT



Preparing the Blank:

- Cut a blank to the length of the tube and add 1/16" for squaring off.
- Drill a 7mm hole lengthwise through the blank.
- Spread glue over the tube, insert into the blank with a twisting motion to spread the glue evenly inside.
- Center the tube lengthwise inside the blanks.
- When the glue is dry, square the ends of the blank. Use a 7mm barrel trimmer. Take the excess material down flush with the ends of the brass tube. (do not trim beyond the length of the tube since this may interfere with the assembly).



Turning the Blank

- Mount the bushings and blanks according to diagram B.
- Thread on the knurled nut and hand tighten to hold all components in place.
- Slide the tailstock up snugly against the mandrel shaft inserting the live center point into the mandrel dimple, lock in place.
- Hand tighten the quill adjustment to firm up the mandrel. (DO NOT overtighten, it could damage the mandrel.)
- Using sharp tools, turn the blank down close to the bushing diameter. Turn the barrel (straight or to a profile of your choice)
- Sand the blank down to be flush with the bushings gradually increasing the sandpaper grits.
- Finish the barrel with your choice of polish. Allow sufficient time for the polish to cure. Refer to polish instructions.

Assembly

- Layout parts according to diagram A
- Press the tip coupler, recessed end in first into the wider end of the barrel.
- Press the stylus nut, recessed end in first into the opening at the opposite end of the barrel.
- Insert the refill into the opening at the stylus end, to bottom. Screw into the stylus nut. Remove the protective cover.
- Screw the tip over the tip coupler.
- Screw the front end over the tip.
- Mount the key ring into the front end eyelet.

Diagram C / Bushings #PKTS100BU

