

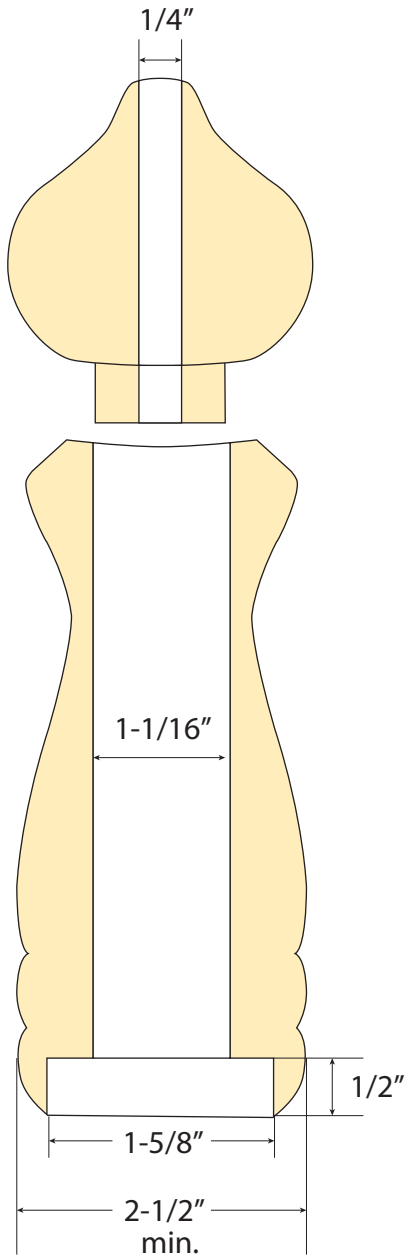

These instructions and dimensions are intended to be used for reference and to help achieve a smooth transition from the top of the mill to the bottom. Your finished mill design results may vary.

Pepper Mill Layout



Salt Shaker Layout

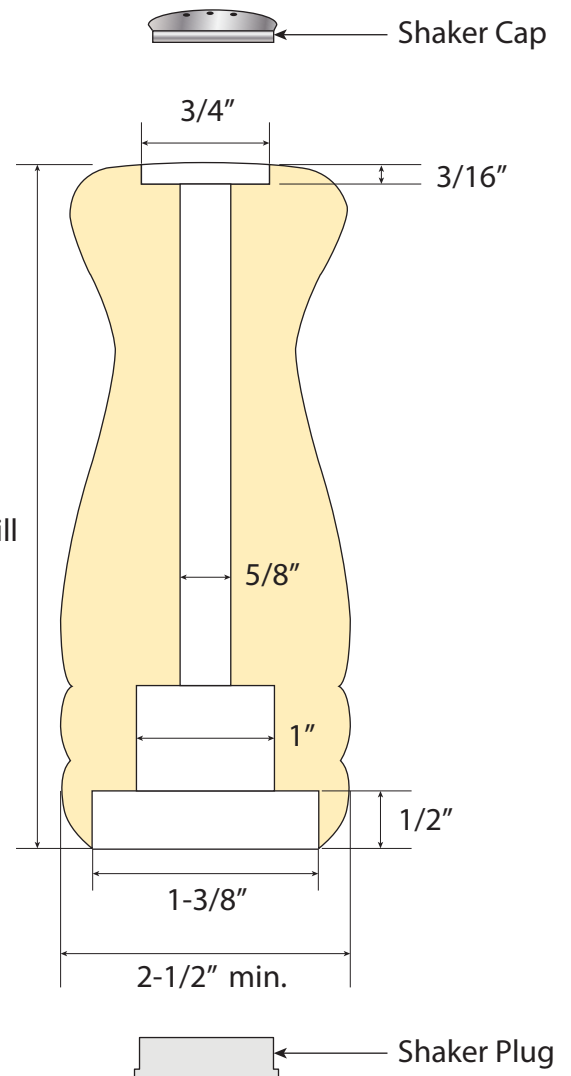

Length varies depending on size of pepper mill

Please read, understand and follow all manufacturers instructions, guidelines and owners manuals that come with your power tools. Ron Brown's Best and its subsidiaries assume no liability for accidents or injuries caused by improper use of this product.



Salt & Pepper Mill Instructions

Tools you will need:

- 1-5/8" Forstner Bit
- 1-1/16" Forstner Bit
- 9" Forstner Bit Extension
- 4 Jaw Lathe Chuck
- 60 degree Live Center
- 1/4" Brad Point Drill Bit

Prepare Mill Head Blank:

1. Mark the center of your mill head blank on both ends.
2. Place mill head blank into lathe chuck and turn a 1-1/16" dia. by 1/2" long tenon on one end of blank.
3. Remove from lathe chuck and drill a 1/4" dia. hole through the center of the mill head blank.

Prepare the Mill Base Blank:

1. Mark the center of your base blank on both ends. Drill a hole on one of the ends that is 1-5/8" in diameter and 1/2" deep. This will be the bottom of the mill.
2. With a 1-1/16" drill bit, drill a hole using the previous hole as your center guide. It is recommended that you drill from both ends of the blank for better results and less wear and tear.

8" Blank Size Reference:

- Base blank size is 6-1/2" in length by min. 2-1/2" x 2-1/2" square.
- Head blank size 2-1/16" in length by min. 2-1/2" x 2-1/2" square

10" Blank Size Reference:

- Base blank size is 8-1/2" in length by min. 2-1/2" x 2-1/2" square.
- Head blank size 2-1/16" in length by min. 2-1/2" x 2-1/2" square.

Figure 1

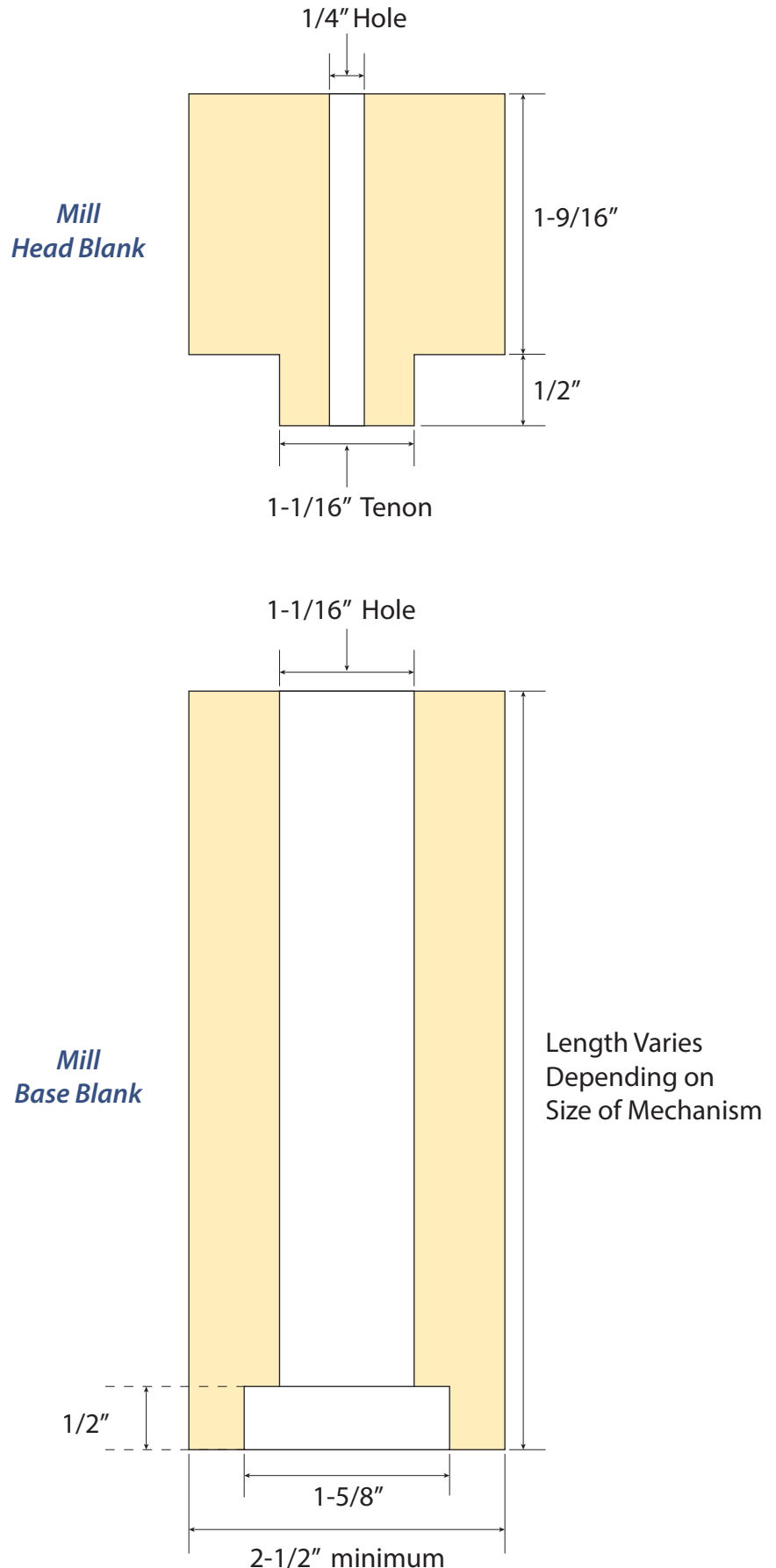



Salt & Pepper Mill Instructions

Figure 2

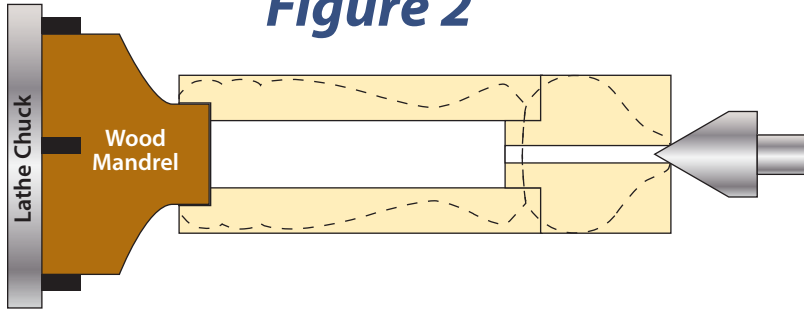

Create a wooden Mandrel

Mount a piece of hard wood in your lathe chuck and create a wooden mandrel that fits the base of the mill blank (see figure 2).

Turning Your Blanks:

1. Place the tenon of the mill head blank into the 1-1/16" hole of the mill base blank.
2. Mount the blank between centers of the wooden mandrel and the live center (see figure 2). Tighten between centers and make sure that it is secured to turn safely.

Caution:

Please note that the tenon of the head blank must fit the base blank hole without any play. A loose fit may cause the final mill to be off center or vibrate when turning produce an undesirable result or possible injury.

3. Turn the wooden blanks to your desired shape or profile of choice. Sand and finish the wood. Be sure to use a food safe finish or polish.

Mill Assembly:

1. Layout mill parts according to diagram shown to the right.
2. Mount the drive disc on the head tenon with the two screws provided.
3. Insert the plastic grinder support into the bottom.
4. Slide the grinder housing on to the drive support.
5. Slide the spring down the drive support to rest on top of the grinder.
6. Insert driver shaft with grinder housing through the turned mill base.
7. Secure the grinder retainer with the two screws that are provided.
8. Secure grind knob to drive shaft. Adjust the tightness of the grind knob for coarse or fine grind.

Shop Note: Be sure to pre-drill for screws, so you do not split the tenon or base of mill.

Grind Knob

Figure 3

