

Basic Universal Shop Stand Instructions

Universal Shop Stands

The Fulton Universal Shop Stands allow you to mix and match a leg set with two stretcher sets to create different sized stands for your shop. The Leg sets come with four legs and all the hardware. The Stretcher sets come with four stretchers and hardware. In order to build your custom stand you need one set of legs and two sets of stretchers. The stretchers can be the same size or two different sizes.

1. Start by assembling the side stretchers to the legs using the square holes on the legs. Your legs have multiple mounting locations at different heights so you can customize the height of your stand. Make sure to face the smaller lip of the stretcher towards the top of your stand.

Using the carriage bolts, fasten the stretchers through the square hole in the legs and through the stretcher and secure with a nut. Repeat this process on the other side of your stand.

With your two sides assembled, attach a washer and nut to the leveler threads. Insert the leveling foot into the holes at the bottom of your stand and secure with the washer and nut on the top side as shown below.

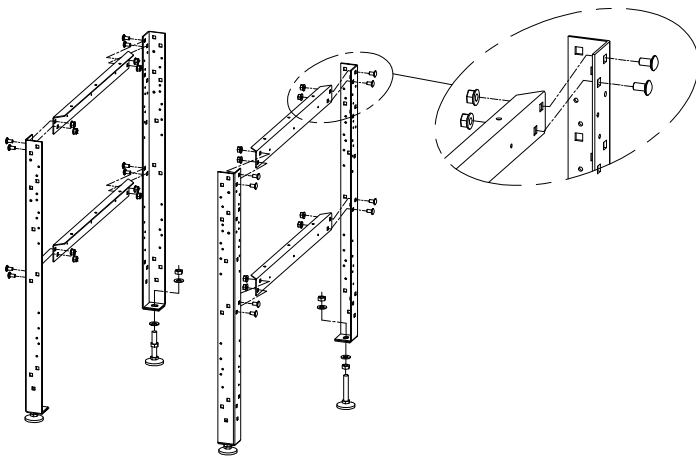

2. Next we will complete the stand by attaching a second set of stretchers to the front and back of the stand following the same process as above.

3. Once you have all the stretchers secured to the legs, go back over each nut to make sure they are all fastened securely.

4. Now you are ready to mount your top to the stand through the pre-drilled hole on the small lip of the stretchers using screws or bolts. Make sure the length of the screw does not protrude through top when fastening.

Shop Note:

You may configure the stand in many different ways for your particular needs. The image below shows the front top stretcher in an offset position. This was done to accommodate for a drawer.



5. Your finished stand should look like the drawing below with your stand complete, adjust each leg leveler for the variations in your floor. We do this by loosening the two nuts on the leveling feet until we have the desired height and then re-secure the nuts.

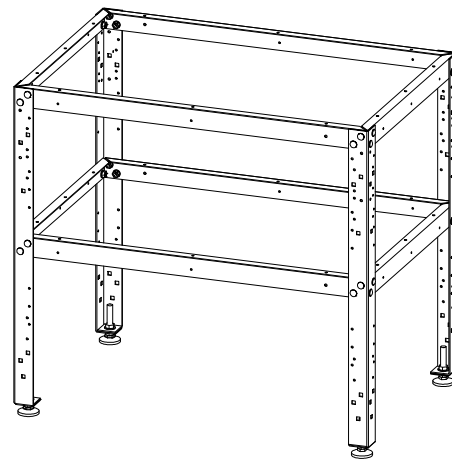

Fulton Woodworking Tools
P.O. box 921487
Norcross, ga 30010