

# PSI Precision Sharpening System for Lathe Chisels

## LCGRIND4

### System Includes

- Long Brace Pole
- Platform Brace Pole
- Grinding Platform
- Fingernail Grinding Jig
- Skew Grinding Jig
- (2) Locking Bases

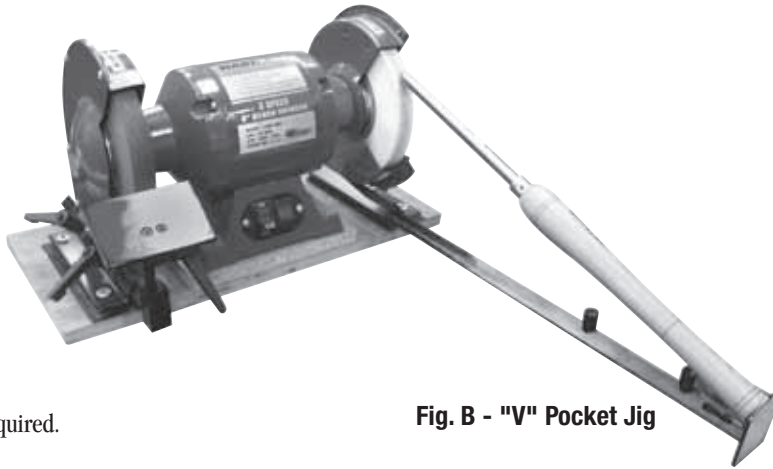

Fig. B - "V" Pocket Jig

### Grinder

- 6" or 8" Bench Grinder is required.

### Mounting (Setting Up the System) (See Fig. A)

- Use a mounting block or set the grinder on your work bench. Use a spacer block under the grinder to add enough clearance for mounting the bases. Mount each base, centered, under the grinding wheels. Allow 1/2" to 1" clearance between the wheel and the top of the base. Line up the front of the base with the grinding wheel. There must be a minimum of 6" from the bottom of the base to the center of the wheel (see Fig. A). On 6" grinder wheels, the grinder base may need to be raised. Secure the bases to the block with 3 screws in each base.
- Insert and slide the long pole into one base slot.
- Insert and slide the platform into the other base slot.
- Attach 2 handles into each base.

### Using the Adjustable "V" Pocket Jig (See Fig. B)

- Use this attachment to sharpen bowl gouges, roughing gouges, scrapers, parting tools and other similar tools.
- Lay the handle of the tool into the pocket of the pole. Rest the blade on the wheel. Move the pole in or out of the slot until the bevel on the blade rests flat on the surface of the wheel. Lock the pole into place.
- Turn the grinder on and lightly touch the bevel of the blade while rolling and conforming to maintain the shape of the bevel. Dip the blade in cold water if it overheats. Hone the blade to eliminate burrs before using.

### Using the Grinding Platform (See Fig. C)

- The platform is best suited for sharpening flat woodworking chisels or other shop and household tools.
- Lay the blade flat, face down, on the platform. Adjust the pole in the slot and the angle of the platform to match the blade bevel of the tool to the wheel.
- Lock the pole and the toolrest in place.
- Turn the grinder on and use a light touch while grinding. Cool the blade and hone.

### Using the Fingernail Jig (See Fig. D)

- This jig is effective when sharpening fingernail blade profiles, especially bowl gouges with long bevels.
- Insert the blade in the slot and lock into place.
- Rest the brace of the jig in the pocket of the pole. Move the pole in or out in the slot to engage the blade with the wheel. Adjust the angle of the holder until the bevel of the blade matches with the grinding wheel. Lock into place. Turn on the grinder. While grinding, maneuver the tool, controlling the long fingernail bevel while rotating the blade from side to side.

Fig. A - Mounting

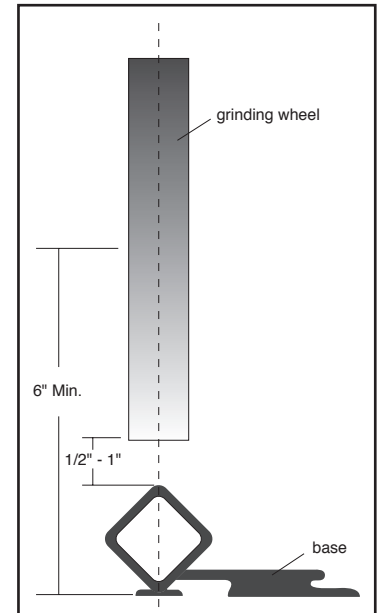

Fig. C - Grinding Platform

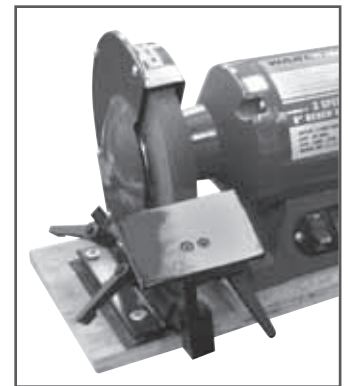

Fig. D - Finger Nail Jig

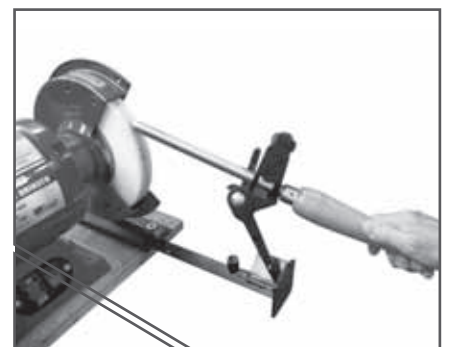

Fig. E- Skew Grinding Attachment

**Using the Skew Grinding Attachment (See Fig. E)**

- Insert the skew jig over the pocket jig end. Lock in place. Place the skew handle in one of the pockets. Slide the pole in or out until the blade of the skew rests flat on the wheel.
- Adjust the pole to match the angle to the wheel. When grinding, use light pressure. Hold the handle steady. Move the skew from side to side to accomplish a perfect, flat, and even edge.



Diagram F- Parts

