

Planer Knife Setting Jig Instructions

IMPORTANT: Before removing your planer knives, read these instructions carefully before proceeding.

If Your Particular Planer Has...

...Knives upto 20" Long

**You should use 2
Planer Knife Setting Jigs**

...Knives 20" or longer

**You should use 3
Planer Knife Setting Jigs**

Planer Jig Setup

Each Planer Knife Setting Jig has a center bar that is adjustable to easily match the height of your Planer Knife. The Jigs also have built in magnets on the side and center bars for convenient placement on to the cutterhead(s). By simply adjusting the center bar to the tip of the Planer Cutter (knife), you can be assured of consistent and accurate results everytime you need to reset your knives. To set the Planer Knife Height Setting Jig Properly - Please carefully read and fully understand the following instructions.

Prepare Your Planer

1. Unplug your planer from the power source.
2. Remove the dust cover from the planer for easier access to the knives.
3. Remove the chip deflector and loosen the springs holding the chipbreaker down, if necessary. Loosening the springs will allow the chipbreaker to be raised to expose a larger portion of the cutterhead.

IMPORTANT: Remember to place each jig at the same position on each knife. If you fail to do so, your knife height could vary from end to end producing inconsistent and undesirable planing results.

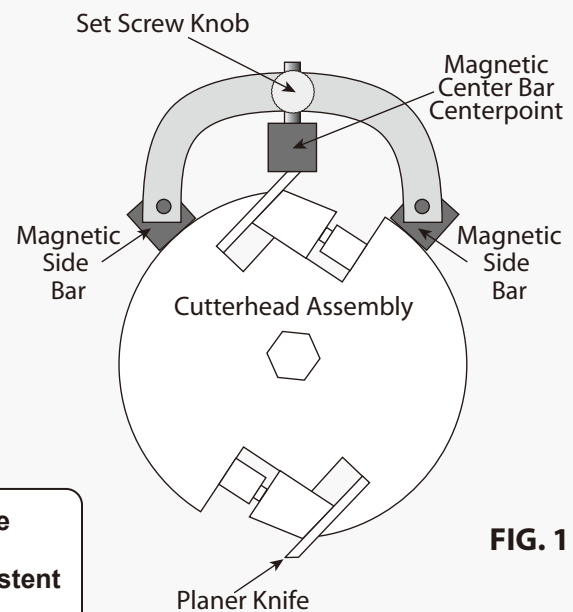

FIG. 1

Setup The Jig(s)

1. Loosen the set screw knobs at the top of the jig that allow the center bar to slide up and down.
2. Place the first jig over a blade right in the center of the cutterhead assembly.
Note: Be sure the center bar touches the knife edge and the side bars contact the cutterhead securely as shown in FIG. 1.
3. Once the jig is properly in position, secure the center bar by carefully tightening the set screw knob.
4. Now, remove the jig and follow steps 1 through 4 with your remaining jigs.
Note: Be sure that you place your additional jigs in the exact same spot on the cutterhead in relation to the first knife. Doing this will result in a near perfect standardization between all of your jigs as you reset or replace your knives.

Setting and Re-Setting Your Planer Knives

With the Planer Knife Setup Jigs set, your knives on your planer can now be reset or replaced. It is recommended to do one knife at a time to achieve the best results.

1. Replace the first knife with your newly sharpened knife. Leave the knife sitting slightly above the others. This is done to allow the jigs to “push” the knife into position. Next, tighten the gib bolts just enough to allow for movement.
2. Place the jig(s) on to one of your knives and gently push down on the jig(s) until the magnets engage the knife. If you are using multiple jigs, each jig should be spaced evenly apart across the length of the knife.
3. Once all of the jigs are in the proper position, secure all the gib bolts one at a time in a gradual manner. Do this by turning each bolt a single time and move to the next bolt. If bolts are not accessible due to jig placement, complete securing all of the other bolts and come back to the hard to reach ones once the accessible ones are secure.
4. Repeat steps 1- 3 in this section for all remaining knives.

Shop Note

It is always a good idea to double check yourself by looking from the side to insure that the center bar is contacting the knife in the proper location as shown in FIG. 1. Doing this each time you set a knife will give you the necessary consistency.

Shop Tips

- When planing your stock you should always alternate the surfaces of your wood when making more than one pass. This is done to maintain uniform stability of your stock on both sides.
- If for some reason your planer knives have been removed prior to setting your planer jigs, there is an alternative setup solution, and it is as follows:
 - Place a Planer Knife Setting Jig directly on the cutterhead.
 - Lower the center bar until the magnets come into contact with the cutterhead.
 - Insert “feeler” guages equal to the knife protrusions (as recommended in your planer machine manual) between the centerbar and the planer cutterhead
 - Tighten the jig set screws.
 - Install your planer knives using the previous steps detailed in these instructions
 - Repeat this process on all of the remaining jigs.
- Now that your knives have all been set and secured into your planer, be sure to re-install the chipbreaker and chip deflector to there respective locations on the planer.

Caution

If for any reason your knives have been re-set higher than before, it is an absolute must that the chip breaker and feed rollers be adjusted so they are below the level of the blades at the bottom of “dead center”. For more information on how make this adjustment, refer to your planers owner manual.