

X-Stender™ For Bessey® K-Body Clamps®

From Peachtree Woodworking Supply, Inc.

1

Remove the stop clips from the ends of two Bessey® clamps .

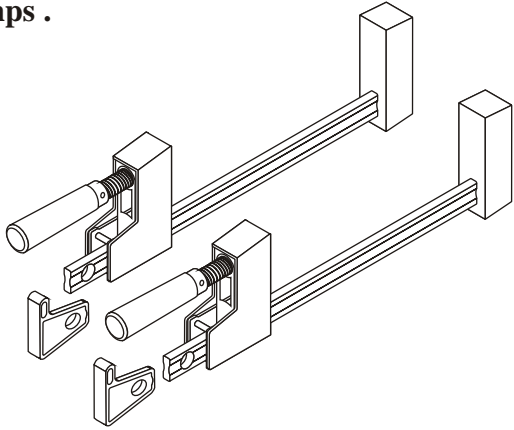

4

Reverse clamping head on 2nd clamp and install with handle just touching clamp end.

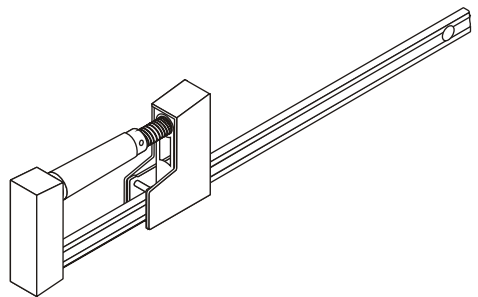

2

Remove the Clamp Head from one Clamp.

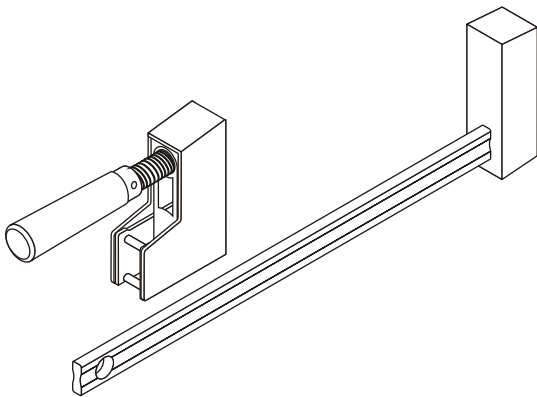

5

Install 2nd clamp in clamp X-Stender™. Align holes in clamp bars with holes in clamp X-Stender™. Install and tighten bolts.

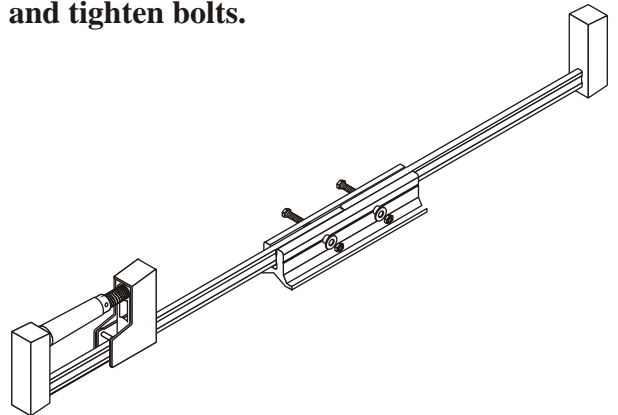

3

Slide the clamp X-Stender™ on to clamp bar.

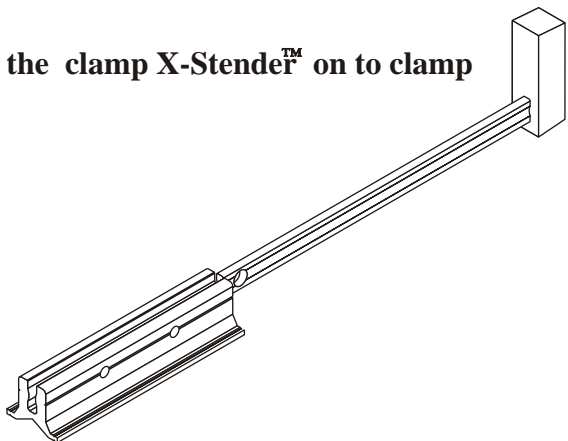

Note:

Early Bessey® K-Body Bar Clamps® will require modification of the bar ends in order to use the X-Stender™

For early K-Body Clamps®:

- (1) Grind off the stop nub on the bar clamp ends.
- (2) Drill 3/8" holes in the clamp bars using the X-Stender™ as the drilling guide.

(Be sure to center the clamps to the center of the X-Stender™ before drilling).



Peachtree Woodworking Supply, Inc.
3250 Oakcliff Industrial Street
Atlanta, GA 30340

www.ptreeusa.com